

The Joint Committee on Taxation of
The Canadian Bar Association
and
Chartered Professional Accountants of Canada

Chartered Professional Accountants of Canada, 277 Wellington St. W., Toronto Ontario, M5V3H2
The Canadian Bar Association, 500-865 Carling Avenue Ottawa, Ontario K1S 5S8

July 25, 2016

Brian Ernewein
General Director, Tax Policy Branch
Finance Canada
90 Elgin Street
Ottawa, ON K1A 0G5

Dear Mr. Ernewein:

Subject: Federal Budget 2016 - Proposed Amendments to Back-to-Back Rules and Section 212.1

We are enclosing a submission which considers the changes to the *Income Tax Act* (the “Act”) announced in the Federal Budget 2016 relating to the proposed expansion of the existing back-to-back rules and the proposed amendments to section 212.1. With respect to the changes to the back-to-back and related rules, we observe that the Budget material did not include draft legislation. Our objective in this submission is to assist you in drafting legislation that addresses the Department’s concerns but at the same time does not interfere with *bona fide* business arrangements.

A number of members of the Joint Committee participated in the discussions concerning this submission and have contributed to its preparation, in particular:

R. Ian Crosbie (Davies Ward Phillips Vineberg LLP)	Mitchell Sherman (Goodmans LLP)
Michael McLaren (Thorsteinssons LLP)	Carrie Smit (Goodmans LLP)
K.A. Siobhan Monaghan (KPMG Law LLP)	Sandra Slaats (Deloitte LLP)
Angelo Nikolakakis (EY Law LLP)	Jeffrey Trossman (Blake Cassels & Graydon LLP)

We would like to thank you for your consideration of this submission. We trust that you will find our comments helpful but would welcome the opportunity to discuss the submission and our concerns with you at your convenience.

Yours very truly,

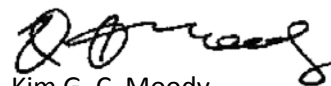

Kim G. C. Moody
Chair, Taxation Committee
Chartered Professional Accountants of Canada

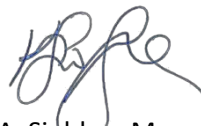

K.A. Siobhan Monaghan
Chair, Taxation Section
Canadian Bar Association

Cc: Robert Demeter, Chief, Business Property and Personal Income, Tax Policy Branch, Finance Canada
Gabe Hayos, Vice President, Taxation, CPA Canada

CBA - CPA Canada Joint Committee on Taxation Submission

Back-to-Back Proposals

In the Budget, four changes are proposed to be made to the “back-to-back” rules in Part XIII. The Budget materials did not include proposed legislation. The purpose of this submission is to assist the Department in developing definitive legislative proposals that do not give rise to unintended or counter-productive consequences.

Existing back-to-back rules

The existing back-to-back loan rules in Part XIII were enacted only recently, in connection with changes to the thin capitalization rules. While not described as such when introduced, in practice, these recently enacted rules operate as a mechanical type of treaty-shopping provision.

Broadly speaking,¹ these rules are engaged where the following conditions are met:

1. A taxpayer (“**Payor**”) pays interest on a debt obligation (the “**Main Debt**”) to another person (“**Intermediary**”);
2. Intermediary is not a non-arm’s length person resident in Canada;
3. Either
 - (a) (i) Intermediary has an amount outstanding on account of an “**Intermediary Debt**” owing to a non-resident person (“**Original Lender**”),
and either,
 - (ii) the Intermediary Debt is limited recourse,
or
 - (iii) it can reasonably be concluded that all or part of the Main Debt became owing or was permitted to remain outstanding **because** all or part of the Intermediary Debt was entered into or was permitted to remain outstanding (the “**causal connection test**”),
or
 - (b) Intermediary has a “specified right” – meaning generally, among other things, a right to mortgage, pledge or otherwise encumber (“**Pledge**”) property to secure payment of debt, including the Intermediary Debt;² and

¹This description summarizes the rules’ key parameters; it does not purport to be comprehensive.

4. The hypothetical withholding tax that would have applied if Payor paid the interest on the Main Debt to Original Lender is higher than the withholding tax payable on the actual interest payments made by Payor to Intermediary.

Where the rules apply, Payor is deemed to have paid interest to Original Lender. The amount of this fictitious payment is based on a formula. The result of this formula is that Payor is treated as if it had paid such an amount of interest to Original Lender as would result in Part XIII tax being payable at the rate that would have applied had the actual interest been paid to Original Lender. This is despite the fact that no actual payment is made by Payor to Original Lender.

These broad rules effectively have two branches:

- (a) a true “back-to-back” branch that may apply where an Intermediary borrows and on-lends to the taxpayer, and
- (b) a second branch involving no real “back-to-back” arrangement, but merely a Pledge by a Canadian borrower under a corporate group’s multi-borrower loan facility that does not meet the Conventional Pledge Exception.

True back-to-back branch

The operation of the true back-to-back branch of the existing rules (and their breadth) is best illustrated through a series of examples.

Example 1

Suppose that, within a corporate group, a Luxembourg company (“**Luxco**”) makes a loan to a Canadian company (“**Canco**”). Suppose Luxco obtained the funds needed to make the loan by itself obtaining a loan from a group company based in Cayman (“**Caymanco**”). In these circumstances, if the causal connection test is met, Canco would be treated as if it had paid interest to Caymanco in such an amount as results in the Part XIII tax rate being elevated from the Luxembourg treaty rate (10%) to the statutory rate (25%). In this fact pattern, the rules operate as a mechanical treaty-shopping regime by negating tax planning that seeks to obtain the benefit of Canada’s tax treaty with Luxembourg.

Example 2

Suppose the facts are the same as Example 1, except that Luxco borrows from an arm’s length bank resident in a non-treaty country (“**Bank**”). In this example, the rules do not apply. This is because the hypothetical withholding tax that would have applied had Canco paid interest to the Bank is zero. Of course, the thin capitalization rules will still apply to limit the amount that can be loaned by Luxco to Canco. Nonetheless, this example illustrates that, at least where there is an arm’s length “original” lender, the existing rule will not apply to impose an additional withholding tax not contemplated by the tax treaty between Canada and Intermediary’s jurisdiction.

²Under an exception (the “**Conventional Pledge Exception**”), if the taxpayer can establish that all the net proceeds upon realization of the Pledge must be used to pay down the Main Debt, then the Pledge is not regarded as a “specified right”.

Example 3

Suppose the facts are the same as Example 1, except that Luxco borrows from a group company resident in Brazil (“**Brazilco**”). In these circumstances, if the causal connection test is met, Canco would be treated as if it had made a fictitious payment of interest to Brazilco, resulting in the withholding tax rate being elevated from the Luxembourg treaty rate (10%) to the Brazil treaty rate (15%). This example illustrates that the existing rules can effectively impose an additional withholding tax not contemplated by either the Luxembourg treaty or the Brazil treaty, since the Brazilian shareholder simply has no Canadian-source income. Indeed, because the rules impose the additional tax through deeming a fictitious payment to be made by Canco to Brazilco, it seems that the rules purport to impose tax in a manner contrary to the Brazil treaty, which permits Canada to tax interest sources in Canada that is **paid to** a resident of Brazil. It is reasonable to expect that in such a situation, competent authority relief may be sought.

Example 4

Suppose the facts are the same as Example 1, except that Luxco funded the Main Debt owing by Canco from its own retained earnings. Suppose the Main Debt is repayable on demand. Suppose that, some time later, Luxco requires funds in order to make an acquisition unrelated to Canada, and borrows money from Caymanco to fund this other acquisition. Is the causal connection test met here? It seems to us that this is debatable. Perhaps the Canada Revenue Agency (“**CRA**”) could assert that the Main Debt was “**permitted to remain owing because**” of Luxco’s borrowing from Caymanco. On the other hand, it seems entirely inappropriate to impose non-treaty withholding tax rates on interest paid by Canco to Luxco where the loan to Canco was funded from Luxco’s retained earnings. This example illustrates the uncertainties created by the causal connection test. In our view, these uncertainties need to be borne in mind in drafting legislative proposals for the proposed extensions of the back-to-back rules.

Second Branch

Under the second branch of the rules, Canco can be deemed to have paid interest to Original Lender in circumstances where it has not in fact paid interest to anyone, but rather has simply provided a Pledge. The Conventional Pledge Exception covers most — but not all - situations that arise in practice. Sometimes under multi-party facilities, for reasons having nothing to do with Canadian tax, the literal requirements of the Conventional Pledge Exception may not be met.³ These fact patterns have nothing to do with avoidance of withholding tax or the thin capitalization rules.

Thus the existing back-to-back rules are already extremely broad. In the context of the Budget proposal to **extend** these already-broad rules, and to use them as a starting point for the extended scope, we submit that it is appropriate to re-consider whether the existing rules appropriately target the mischief at which they are aimed, and to consider refinements to ensure these rules do not produce inappropriate or anomalous results. We would be pleased to provide further input into the fact patterns where we believe inappropriate results can arise.

³ For example, in order to avoid adverse US tax consequences, the ability to apply proceeds on a realization of the pledged assets to extinguish debt owing by a US parent may be limited. This is discussed further in Section 5 below.

Proposed Extension of Back-to-Back Rules

1. Rents, Royalties and Similar Payments (“Royalties”)

The Budget proposes to extend the back-to-back rules to apply to Royalties.

The new rules will apply where:

- (a) Canco makes a Royalty payment in respect of a particular lease, license or similar agreement (the “**Canadian leg**”) to a “person or entity” resident in a treaty country (“**Intermediary**”);
- (b) Intermediary has an obligation to pay an amount to another non-resident person (“**Original Licensor**”) in respect of a lease, license or similar agreement, or of an assignment of an instalment sale (the “**second leg**”);
- (c) Either
 - (i) the amount payable by Intermediary is established in whole or in part by reference to (x) the Royalty paid by Canco, or (y) the fair market value of property; any revenue, profits, income or cash flow from property; or any other similar criteria in respect of property, where a right to use the property is granted under the Canadian leg (the “**amount payable test**”); or
 - (ii) it can reasonably be concluded based upon all the facts and circumstances that the Canadian leg was entered into or permitted to remain in effect because the second leg was, or was anticipated to be, entered into (the “**causal connection test**”). In this regard, the fact that the Canadian leg and the second leg are in respect of the same property would generally not be considered sufficient on its own to support the conclusion that this condition has been met; and
- (d) The hypothetical withholding tax that would have applied if Canco paid the Royalty on the Canadian leg to Original Licensor is higher than the withholding tax payable on the actual Royalty payments made by Canco to Intermediary under the Canadian leg.

The new rule is proposed to apply to Royalty payments made after 2016.

We have several observations on this proposal, as follows:

(a) Rules should not apply to arm’s length situations

Unlike arm’s length interest payments, arm’s length Royalty payments to non-residents are generally subject to withholding tax under domestic law.

We would therefore respectfully suggest that these rules should be limited to situations where Original Licensor is in the same corporate group as Canco and Intermediary. This would more appropriately target conduit-type arrangements. Without this limitation, the rules will be extremely broad, calling into question the availability of treaty exemptions or treaty-reduced rates in virtually every arm’s length inbound license.

For example, suppose Canco obtains a software license from a US resident arm's length "Intermediary". Under the Canada-US treaty, software royalties are exempt. To protect itself from potential application of these rules, Canco will need to request a representation from Intermediary that it did not acquire its rights under a second leg (that meets the amount payable test or the causal connection test) from another entity resident in a country that does not have a treaty with a software royalty exemption – say Israel. In many cases, due to asymmetrical negotiating power, Intermediary will resist any such request, as it is in many contexts extremely unconventional and effectively seeks information on Intermediary's internal arrangements which Intermediary may not be prepared to share with customers. Moreover, the Intermediary may have itself acquired the software from an arm's length seller for a purchase price that includes an earnout tied to Intermediary's earnings from licensing the software. It would seem entirely inappropriate for Canada to impose a withholding tax on the basis of the amount payable test in such circumstances.

Having no information about whether Intermediary has a back-to-back arrangement with another group entity – or an arm's length entity – which might or might not have any or the same treaty protection, Canco's only option to protect itself is to withhold at 25%. Intermediary will in many cases insist that this cost be borne by Canco. And Canco will have no means to recover the tax from the "real" non-resident taxpayer (the Original Licensor), with which it has no dealings and which it cannot identify. So the net result in practice will inevitably be that Canco faces a higher cost of accessing computer software. In other words, we suspect that new taxes raised by this measure will be borne, to a significant extent, by Canadian users of technology.

The same issue would arise even if the Royalties paid by Canco to Intermediary were not exempt from Canadian withholding tax. For example, consider a trademark royalty paid to an arm's length Irish resident "Intermediary". If that "Intermediary" was itself obligated to make Royalty payments to, say, an Israeli company in circumstances where the causal connection test is met, Canco would be exposed to the higher rate of tax (15%) under the Israeli treaty, as opposed to the 10% rate in the Irish treaty. Again, Canco would have no ability to recover the additional tax, or even to know that it was payable. So Canco's cost of accessing the trademarks would be increased.

We do not believe these rules were intended to increase the cost to Canadian companies of accessing intellectual property from global multinationals; yet, we see this as a likely result if the measure is not confined to non-arm's length situations. This problem does not arise under the existing back-to-back rules because arm's length interest payments enjoy a domestic law exemption.

Recommendation:

The back-to-back rules should not be extended to royalties paid or credited to a person dealing at arm's length with the payor.

(b) Rules should apply only to rents, royalties, similar payments, not more broadly

Paragraph 212(1)(d) imposes withholding tax on a wide range of payments that go beyond rents, royalties and similar payments, such as:

- (i) “knowhow” payments where the consideration depends on use, sales, profits or similar measures,
- (ii) payments for certain services where the consideration depends on use, sales, profits or similar measures,
- (iii) consideration for an agreement not to use intellectual property or “knowhow”,
- (iv) any sort of payment, including an instalment on the sale price of property (other than agricultural land) that is dependent on use of or production from property in Canada.

We are concerned by the reference to “an assignment of an instalment sale” in the description of the second leg. This seems to be a reference to the broader tax base described in paragraph 212(1)(d). The legislative proposals should be limited to payments that are in fact rents, royalties and similar payments.

Consider a situation where Canco makes payments to an arm’s length service provider resident in the United States (referred to below as “Intermediary”), where the service fees are based partially on sales. Under the US treaty, the payments to Intermediary are exempt from Part XIII withholding tax as business profits (assuming, as we do, that the requirements of the limitation-on-benefits (“**LOB**”) rules are met). Suppose that, without Canco’s knowledge, Intermediary sub-contracts all or a portion of its obligations to a company in Intermediary’s group that is resident in Bermuda in circumstances where the causal connection test is met (referred to below as “Original Licensor”). Hypothetical payments to Original Licensor would have been subject to 25% withholding tax, and therefore Canco is again exposed to an assessment of 25% withholding tax in this situation. Again, Canco has no capacity to recover this tax from Intermediary or Original Licensor, and therefore the effect is simply to increase Canco’s cost of doing business. This is especially inappropriate given that the Canada-US treaty already has a comprehensive LOB article which, by hypothesis, has been complied with.

Many other examples could be cited (such as situations involving instalment payments and any other amounts of which vary with use of or production from property). Our point here is that, because of the breadth of paragraph 212(1)(d), as a definitional matter, the types of payments to which the new rules should apply should be limited to true rents, royalties and similar payments, and not the farbroader taxing base described in paragraph 212(1)(d).

Recommendation:

The extension of the back-to-back rules should be limited to payments that are “rents, royalties and similar payments”, and should not extend to other payments that may be taxable under paragraph 212(1)(d).

(c) Causal Connection test should be re-considered in context of royalties

While the causal connection test may make sense in the context of back-to-back loans, we question whether it is appropriate in the context of royalties. We welcome the clarifying comment stating that the mere fact the two legs relate to the same property will not be sufficient to establish a causal connection. But we wonder what types of situations would then

be caught. Since this rule appears to be intended to be an anti-avoidance rule, we suggest that the rule should apply only where a tax avoidance purpose is present. This would provide at least some check on the potential over-breadth of the rule. If instead the rule is purely mechanical, there will inevitably be considerable uncertainty as to its scope.

Recommendation:

The extension of the back-to-back rule to royalties should be limited to fact patterns where a tax avoidance purpose is present.

(d) Treaty Override

As noted above, the existing back-to-back rules may in some cases give rise to taxation that is not in accordance with Canada's treaty obligations. However, as arm's length interest typically benefits from a statutory exemption from withholding tax, the existing back-to-back rules may effectively be limited to circumstances in which, within a non-arm's length group, there is a back-to-back arrangement.

Because of the facts that:

- (i) arm's length royalty payments are not generally treaty exempt,
- (ii) Canada's treaties vary considerably in terms of the extent to which certain kinds of royalties are exempt from source state taxation,
- (iii) there are different treaty rates for royalties in different treaties, and
- (iv) the domestic "royalty" base in paragraph 212(1)(d) is extremely broad,

there may be a much wider range of situations in which application of these new rules will result in taxation that is not in accordance with existing treaty commitments.

Recommendation:

We recommend that the scope of these new rules be limited (in the manner described above) in order to reduce the incidence of these problems.

2. Character Substitution Rules

The Budget proposes to enact new character substitution rules. The stated purpose of these rules is to prevent circumvention of the other back-to-back rules through the "substitution of economically similar arrangements" between an intermediary and another non-resident person. This suggests that these rules are fundamentally supporting rules to the existing rules.

Three specific targeted situations are identified:

- (a) where interest is paid by a Canadian-resident person to an intermediary and there is an agreement that provides payments in respect of royalties between the intermediary and a non-resident person;

- (b) where royalties are paid by a Canadian-resident person to an intermediary and there is a loan between the intermediary and a non-resident person; and
- (c) where interest or royalties are paid by a Canadian-resident person to an intermediary and a non-resident person holds shares of the intermediary that include certain obligations to pay dividends or that satisfy certain other conditions (e.g., they are redeemable or cancellable).

In each of these cases, the Budget proposals state the rules will apply only where a “sufficient connection is established” between the applicable legs. The presence of such a connection “will be determined by applying tests similar to” those used in the interest and royalty rules, but “adapted” to reflect the relevant circumstances.

Where the rules apply, an additional fictitious payment will be deemed to have been made by the Canadian taxpayer to the ultimate lender/licensor/shareholder.

Our initial observations on this proposal are as follows:

- (a) The rationale for these rules is stated to be to prevent circumvention of the principal rules. Yet, these rules would apply even where there is no tax avoidance motive. In other circumstances in the Act where rules are enacted to preserve the integrity of a basic rule, it usually must be shown that a purpose of a transaction was to defeat the main rule. In our view, it would be appropriate to have such a requirement here as well, particularly as the principal rule does not itself have a purpose test. Otherwise, we foresee a high risk that taxpayers will innocently fall into these rules in benign situations.

For example, suppose Intermediary is resident in a treaty jurisdiction, is funded with preferred shares, and uses the proceeds to make a loan to Canco. Suppose the preferred shares were in fact the most appropriate funding mechanism in Intermediary’s jurisdiction for reasons having nothing to do with tax (i.e., the dividends on the preferred shares are not deductible). Under this rule, if the “connection” test is met, Canco will be treated as having paid interest to the holder of the preferred shares. If that holder is within the corporate group, withholding tax will apply, typically at a 10% rate (unless the shareholder is a qualifying US resident). The imposition of tax on a fictitious payment by Canco to the shareholder is, in our submission, entirely arbitrary. It also constitutes taxation of the shareholder in a manner not contemplated by the shareholder’s country’s tax treaty with Canada, as the shareholder simply has no Canadian-source income.

Recommendation:

The “character substitution” back-to-back rules should be limited to fact patterns where a tax avoidance purpose is present.

- (b) These rules should also be confined to non-arm’s length situations. The scope for overreach in arm’s length situations is immense.

For example, suppose Licensor, a resident of the US, acquires computer software under a transaction where it borrows funds from an arm’s length Bermuda bank. Licensor grants Canco the right to use the computer software in exchange for a royalty. Under the Canada-US treaty, the royalty is exempt from Canadian tax. While we would hope the “connection” test would not

be met in such a case, if it is met, it seems Canco would be treated as having made a fictitious computer software royalty payment to the Bermuda bank. Such a hypothetical payment would be subject to 25% withholding tax. It is wholly inappropriate for such tax to be imposed just because of the “connection” between the arm’s length borrowing and the royalty stream.

Recommendation:

The “character substitution” back-to-back rules should not apply to amounts paid or credited to a person dealing at arm’s length with the payor.

- (c) More generally, we question the soundness of the premise that royalties and interest are “economically similar”. Royalties generally depend on some measure such as sales or revenue. Interest (other than participating interest) is different; it is a return to the lender calculated based on a fixed or floating rate on a stipulated principal sum. While we understand the desire to have a protective rule to address situations where taxpayers circumvent the main rules, we believe a mechanical character substitution rule is built on a questionable premise. We fear that it will lead to inappropriate outcomes, resulting in increases in the cost to Canadian businesses of accessing capital or intellectual property.

3. Back-to-back Shareholder Loan Rules

New rules are proposed to supplement the upstream shareholder loan rules in subsection 15(2) of the Act. The premise of these rules appears to be a concern that taxpayers have an incentive to use a back-to-back arrangement to avoid application of subsection 15(2) by routing an upstream loan through a third party. This too suggests that these rules are intended as supporting rules, designed to preserve the integrity of subsection 15(2).

According to the Budget documents, the new rules will apply in respect of a corporation resident in Canada (“CRIC”) where an “Intermediary” that is not connected with a shareholder of the CRIC is owed an amount (“Shareholder Debt”) by the shareholder, and:

Either:

1. Intermediary owes an amount (“Intermediary Debt”) to CRIC, and

either:

(a) the Intermediary Debt is limited recourse to the Shareholder Debt, or

(b) it can reasonably be concluded that the Shareholder Debt became owing or was permitted to remain owing **because** the Intermediary Debt was, or was anticipated to be entered into (the “causal connection test”);

or

2. Intermediary has a “specified right” in respect of a particular property that was granted by CRIC, and either the existence of the specified right is required under the Shareholder Debt, or the amount was permitted to remain owing because the specified right was or was anticipated to be granted.

The Budget documents state that “specified right” will have the same meaning as in the existing back-to-back rules. Where the rules apply, the shareholder will be deemed to owe an amount to CRIC.

The Budget documents state that these new rules will apply to all arrangements in place on Budget Day.

We have the following comments:

- (a) While these proposals may superficially resemble the existing back-to-back rules, they are in fact quite novel, and will require substantial new legislative drafting. It is inappropriate for these rules to apply as of Budget Day in the absence of detailed legislation. Instead, we submit that, like the other new measures, these proposals should apply only after 2016.

Recommendation:

The back-to-back shareholder loan rules should apply only to debt incurred after 2016 (or such later time when definitive legislative proposals are released publicly for the first time).

- (b) These rules may treat a direct or indirect shareholder of a CRIC that has never borrowed any money from the CRIC as if it received a Canadian-source deemed dividend. For example, suppose that, under a multi-party facility, a non-resident “Parent” of a CRIC and one or more other group companies borrow money from an arm’s length bank in circumstances where CRIC provides a pledge of its assets as security for a guarantee of all such debt. Suppose the pledge arrangement constitutes a “specified right”, which might arguably occur in certain circumstances where, upon realization of the pledge, it is not necessary that 100% of the proceeds be applied to extinguish all of the principal debt, so that the Conventional Pledge Exception arguably does not apply (which may occur for reasons having nothing to do with Canadian tax). In that case, it appears that under the second branch of the new rules, “Parent” will be treated as if it had borrowed money from CRIC, and if that fictitious loan remains outstanding for a sufficient period of time, Parent will be deemed to have received a Canadian-source dividend, and will be subject to withholding tax thereon. Parent of course actually has no Canadian-source income. The imposition of such tax would therefore be taxation that is not in accordance with Canada’s treaty commitments. This application of these rules may well be met with a competent authority application under Canada’s treaty with Parent’s country of residence. Moreover, in the context of an actual shareholder loan, the withholding tax may be refunded when the loan is repaid. Where there is no actual loan, it is not clear how (or whether) the withholding tax would be refunded.

Recommendation:

The back-to-back shareholder loan rules should not apply except where the purpose of the arrangements is to avoid the shareholder loan rules.

- (c) These rules appear to have the effect of penalizing Canadian companies that enter into notional cash pooling arrangements. Under these arrangements, no loans are actually made by the Canadian corporation in a multinational group. Rather, the arrangement with the group’s bank is typically that overall balances will be netted for purposes of determining whether an overdraft or credit position exists. These arrangements are commercially motivated, not tax motivated.

They are common, and, we believe they do not offend the underlying tax policy of preserving the integrity of subsection 15(2). This proposal upends these arrangements immediately, without notice, and without any opportunity for consultation. We strongly recommend that Finance defer the application of the new rules to notional cash pooling arrangements and that it engage in consultations with affected taxpayers before enacting these provisions, with a view to determining whether a suitable carve-out for non-tax motivated notional cash pooling arrangements can be developed.

Recommendation:

The application of the shareholder loan back-to-back rules to notional cash pooling arrangements should be deferred until completion of consultations with affected taxpayers, with a view to determining whether a suitable carve-out for non-tax motivated notional cash pooling arrangements can be developed.

- (d) These rules are novel and potentially far reaching. We cannot at this point think of all of the potential fact patterns in which these rules will produce unintended consequences. But we believe that, depending upon the way in which these rules are enacted, there could be many such situations. As the purpose of these rules appears to be to preserve the integrity of subsection 15(2), we submit a more appropriate approach would be to add a provision under which these rules would apply only where one of the purposes of a transaction is to circumvent subsection 15(2). This would more effectively target the situations of concern, and would mitigate the likelihood of unintended consequences.

Recommendation:

The shareholder loan back-to-back rules should apply only where one of the purposes of a transaction is to circumvent subsection 15(2).

4. Multiple Intermediary Structures

The Budget documents indicate a further clarifying change is proposed to apply to so-called multiple intermediary structures.

The precise scope of the legislative changes is not clear at this time, but this proposal appears to have the potential to create far reaching implications that could impact non-tax motivated structures.

We would generally reiterate the same comments noted above with respect to this proposal.

5. Issues with the Existing Back-to-Back Rules

As mentioned above, some problems arise with the existing legislation and, given that amendments are proposed to expand the scope of the back-to-back rules, we recommend that the amendments include relief for the following two issues.

a) Potential Problems with “specified right” definition

Suppose US Parent has two wholly owned subsidiaries – “Canco” and “UKco”. Suppose the group enters into a multi-party lending facility with an arm’s length syndicate of banks.

Suppose each member of the group provides a secured guarantee of all of the indebtedness of each other member of the group’s debt (and pledges its assets in support of the guarantee), **except that** for US tax reasons, neither Canco nor UKco guarantees the debt of US Parent.

Suppose all three companies draw down on the facility and pay interest to the banks.

In this case, some practitioners have been concerned that the exclusion at the end of the definition of “specified right” does not work appropriately when applied to the security interest provided by US Parent. In particular, the question has been raised as to whether it is sufficiently clear that “all of the proceeds” from a realization on US Parent’s pledge must first be applied to reduce amounts described in subparagraph 18(6)(d)(i) or (ii). This is because the proceeds of that pledge can be applied to the debt of UKCo, and there is uncertainty about whether UKCo’s debt is described in subparagraph 18(6)(d)(ii). The uncertainty arises because the UKCo debt appears to be a debt obligation referred to in clause 18(6)(d)(ii)(A), but not every security interest securing UKCo’s debt secures every other debt obligation under the credit facility, which is required by clause 18(6)(d)(ii)(B).

While we acknowledge that the matter is not entirely clear, we think that a careful reconsideration of the “specified right” definition is appropriate before steps are taken to use the same concept in the proposed extensions of the back-to-back rules.

b) BTB Loans and Related Party Creditors

Paragraph 212(3.1)(e) contains the *de minimis* rules applicable to the withholding tax elements of the existing back-to-back loan regime. The *de minimis* exception will apply to prevent the application of subsections 212(3.2) and (3.3) to a payment of an amount in respect of a particular debt (a “particular debt”) to a person (the “intermediary”) where the total of all amounts outstanding as an “intermediary debt” or the fair market value of a property in which a “specified right” was granted is less than 25% of the total of two amounts.

Subparagraph 212(3.1)(e)(i) describes the first of these amounts as the amount outstanding as the particular debt owed to the intermediary. Subparagraph 212(3.1)(e)(ii) describes the second as the total of all amounts (other than amounts outstanding as the particular debt owed to the intermediary) that the taxpayer or a non-arm’s length person has outstanding on account of a debt to pay an amount to the intermediary under the agreement (or a connected agreement) where certain specified security is provided.

We are concerned that subparagraph 212(3.1)(e)(ii) inappropriately limits the availability of the *de minimis* exception in the context of group credit facilities provided by an intermediary and other non-arm’s length members of the intermediary group. In particular, subparagraph 212(3.1)(e)(ii) only includes amounts that the taxpayer and non-arm’s length persons have outstanding to the intermediary itself. The rule does not include amounts that the taxpayer and non-arm’s length persons have outstanding to other members of the intermediary group.

This limited application can give rise to unexpected results. For example, non-resident parent loans \$20 million to the intermediary, the intermediary loans \$20 million to the taxpayer and a wholly-owned subsidiary of the intermediary (“Subco”) loans \$80 million to the taxpayer, all as part of the same financing transaction. Assume that the \$20 million advanced by the non-resident parent to the intermediary would be considered an “intermediary debt” in respect of both the amount owing by the taxpayer to the intermediary and the amount owing by the taxpayer to Subco.

The *de minimis* exception would not apply to payments made by the taxpayer to the intermediary in this case because the intermediary debt is equal to 100% of the amount of the particular debt owing to the intermediary. Similarly, the *de minimis* exception would not apply to payments made by the taxpayer to Subco because the intermediary debt is equal to 25% of the amount of the particular debt owing to Subco. This is the result notwithstanding that only 20% of the amount advanced to the taxpayer was sourced from the taxpayer’s non-resident parent.

We believe that this result conflicts with the policy rationale for the exception, which is stated as preventing the application of subsection 212(3.2) where the particular debt is funded by the intermediary mainly from sources other than the non-resident parent.

Similar comments are applicable to the *de minimis* exception in subparagraph 18(6)(d)(ii).

Recommendation:

We recommend that subparagraph 212(3.1)(e)(ii) be amended to include amounts that the taxpayer and non-arm’s length persons have outstanding as or on account of a debt or other obligation to pay an amount to the intermediary “or to a person or partnership that does not deal at arm’s length with the intermediary”.

We also recommend that subparagraph 18(6)(d)(ii) be amended in a similar manner.

Cross-Border Surplus Stripping

Budget 2016 includes a proposal to significantly restrict the application of the exception (the “**Exception**”) in subsection 212.1(4) to the cross-border surplus stripping rule (the “**Main Rule**”) in subsection 212.1(1). While we acknowledge the Government’s prerogative to establish and to change tax policy, and to amend the Act accordingly, we are concerned that this proposed amendment, as well as comments included in Budget 2016, may have unintended and inappropriate tax consequences in a variety of contexts.

The Main Rule applies where certain conditions are met. These are as follows:

- a non-resident person (or a designated partnership or a non-resident-owned investment corporation (referred to as the “non-resident person”)) disposes of shares (referred to as the “subject shares”) of any class of the capital stock of a corporation resident in Canada (referred to as the “subject corporation”) to another corporation resident in Canada (referred to as the

"purchaser corporation") with which the non-resident person does not (otherwise than because of a right referred to in paragraph 251(5)(b)) deal at arm's length, and

- immediately after the disposition, the subject corporation is connected (within the meaning that would be assigned by subsection 186(4) if the references in that subsection to "payer corporation" and "particular corporation" were read as "subject corporation" and "purchaser corporation", respectively) with the purchaser corporation.

Where it applies, a deemed dividend can arise, and/or the paid-up capital ("PUC") of any shares of the purchaser corporation issued by it as consideration for the subject shares (the "PC shares") may be reduced, to the extent that any non-share consideration and/or the PUC of the PC shares exceeds the PUC of the subject shares.

The Exception applies where the purchaser corporation controlled the non-resident person⁴ immediately before the disposition. Thus, where the purchaser corporation controls a non-resident corporation that holds the subject shares (i.e., there is a "sandwich" structure), the Exception enables the "sandwich" structure to be unwound, as noted in Budget 2016.

Budget 2016 states as follows:

An exception to this anti-surplus-stripping rule is found in subsection 212.1(4). It applies where a Canadian corporation (the "Canadian purchaser corporation") acquires shares of a non-resident corporation that itself owns shares of a Canadian corporation – that is, where the non-resident is "sandwiched" between the two Canadian corporations – and the non-resident disposes of shares of the lower-tier Canadian corporation to the Canadian purchaser corporation in order to unwind the sandwich structure.

Some non-resident corporations with Canadian subsidiaries have misused this exception by reorganizing the group into a sandwich structure with a view to qualifying for this exception, as part of a series of transactions designed to artificially increase the PUC of shares of those Canadian subsidiaries.

Budget 2016 proposes to amend the exception in subsection 212.1(4) to ensure that it applies as intended. In particular, it will be clarified that, consistent with the policy of the anti-surplus-stripping rule, the exception does not apply where a non-resident both (i) owns, directly or indirectly, shares of the Canadian purchaser corporation, and (ii) does not deal at arm's length with the Canadian purchaser corporation.

While we agree with the proposition that the Exception is intended to apply "where a Canadian corporation ... acquires shares of a non-resident corporation that itself owns shares of a Canadian corporation", we respectfully submit that the proposed restriction, as currently drafted, is not consistent

⁴ In the context of the exception, the non-resident person must be a corporation.

with the policy of the Main Rule and cannot reasonably or accurately be characterized as a clarification of the law.⁵

Rather, it is submitted that this proposed restriction, as currently drafted, would introduce unwarranted and unintended discrimination – a form of protectionism – into the application of the Exception in relation to *bona fide* arm’s length acquisition transactions. In addition, we are concerned that this proposed restriction could produce inappropriate consequences both in contexts where there is a *bona fide* arm’s length acquisition and in contexts where there is a *bona fide* reorganization transaction.

The discussion which follows sets out our understanding of the legislative history of section 212.1, as well as our analysis of the impact of subsection 212.1(4) with respect to the Canadian tax base in situations where the ultimate parent corporation is a Canadian-resident rather than a non-resident. Our analysis demonstrates objectively that the residence of the ultimate parent corporation makes no difference in terms of the impact on the Canadian tax base. Thus, no such distinction should be made in tax policy terms or assumed to have been intended by the legislature in enacting subsection 212.1(4).

Legislative History

The legislative history of the Main Rule and of the Exception date back to 1977 and 1978. These provisions were introduced as part of a “major reform” that was intended to replace the “designated surplus” and related rules because those rules were considered to “often hamper constructive business reorganization and expansion”.⁶ The purpose of these changes, and the comments in this regard in the 1977 Budget, must be viewed in their historical context.

The problem of “surplus stripping” – and attempts to address it, and even to define it – have had a very long history in Canadian tax law. As noted in the Carter Commission Report, the “definitional difficulty is in distinguishing a normal sale from a sale which is part of a contrived scheme”.⁷ The Carter Commission Report also described the history and effect of the “designated surplus” rules, as well as their historical context.⁸

Post-1948 Legislation

The introduction of the Income Tax Act in 1948 resulted in major changes in tax legislation, including the elimination of most ministerial discretion. Those subsections of section 32A directed specifically at surplus-stripping and certain other sections dealing

⁵ We note that these statements were relied on by the Tax Court of Canada in the recent decision in *Univar Holdco Canada ULC v. The Queen*, June 22, 2016 (2013-2834(IT)G). We also note that this decision is on appeal to the Federal Court of Appeal.

⁶ See Budget Document, March 31, 1977, page 35. See also the related Supplementary Information document.

⁷ Canada, *Report of the Royal Commission on Taxation* (Ottawa: Queen's Printer, 1966).

⁸ *Ibid*, Volume 4, Appendix D. This history is also described in detail in many articles that have been published over the years.

with that subject were withdrawn and subsequently replaced by the new concept of "designated surplus". In general terms, the new legislation provided that where one corporation acquired control of another at a time when the acquired corporation had undistributed income on hand, such undistributed income would become "designated surplus", and that dividends paid out of this surplus would not be exempt from tax in the hands of the controlling corporation. The prohibitive tax that would ordinarily result from applying normal corporation tax rates to such a dividend indicates that the legislation was intended to prevent avoidance rather than raise revenue.⁹

In other words, the "designated surplus" rules were designed, among other things, to curtail the use of a freshly capitalized acquisition company to acquire the shares of a target company that had "undistributed income on hand".

As noted in the Carter Commission Report, these rules took the somewhat unorthodox approach of foisting an adverse tax consequence on the purchaser corporation in an attempt to indirectly tax the seller(s), which resulted in an undesirable interference not only with *bona fide* acquisition transactions but also *bone fide* reorganization transactions:¹⁰

In this and other situations, the somewhat indirect approach [fn 12] of the designated surplus concept has interfered with normal and very often desirable corporate reorganization while at the same time failing in its principal purpose.

Footnote 12 noted the following:

The approach is indirect in that it levies a tax, at least potentially, on the purchaser of the shares in an attempt to reach the seller and presumed recipient of the benefit of the undistributed income.

As noted above, this approach was abandoned through the "major reform" that occurred under the 1977 Budget. The basic architecture of the new regime was designed to reflect the parameters of the definitional proposition stated in the Carter Commission Report – namely, "distinguishing a normal sale from a sale which is part of a contrived scheme".

It is in this context that the Main Rule and the Exception must be understood. The Exception was introduced in 1978, with retroactive effect back to March 31, 1977, not to defeat the purpose of the Main Rule but to fulfill its underlying rationale. The Exception fulfills this rationale by displacing the technical application of the Main Rule in contexts where there is a non-arm's length transfer as part of a post-acquisition reorganization that follows a *bona fide* arm's length acquisition transaction, in accordance with the basic policy decision to stop foisting an adverse tax consequence on the purchaser corporation.

⁹ *Ibid.*

¹⁰ *Ibid.*

Furthermore, there is no evidence that this policy decision, as reflected in the structure of the Main Rule and the Exception, was intended to be restricted to purchaser corporations that had only Canadian-resident shareholders, or to exclude *bona fide* purchaser corporations that had non-arm's length non-resident shareholders. On the contrary, one concern under the previous "designated surplus" rules was that their operation could in fact favour non-resident purchasers, unless resident purchasers resorted to alternative post-acquisition planning, in which case the operation of the rules could favour the latter. The following is noted in the Carter Commission Report:¹¹

It has been suggested that the designated surplus concept puts non-resident corporations in an advantageous position as compared with resident corporations when competing for the acquisition of a Canadian corporation which has a substantial surplus. In the event that the acquired corporation was to continue its operation in its present form and not to make distributions in excess of current earnings, the complaint would not be valid because no immediate tax on the surplus would be incurred by either party. However, in the event that the acquired corporation was to be wound up, the tax cost could be 26.1 per cent of the surplus for the non-resident corporation, [fn 13] and 50 per cent of the surplus for the resident corporation. [fn 14] But it is not likely that the resident corporation would submit to the 50 per cent tax. Instead, one of the other methods of distribution for which provision is made in the Act would probably be used so that the tax cost would be less than that of the non-resident corporation.

In either case, the operation of the "designated surplus" rules could have had the undesirable effect of creating an unlevel playing field for resident or non-resident purchasers when competing for the acquisition of a Canadian-resident corporation which had substantial undistributed surplus. In contrast, the "major reform" introduced under the 1977 Budget, and the subsequent retroactive introduction of the Exception to the Main Rule, made no such distinction and thus created a level playing field between resident and non-resident purchasers in the context of *bona fide* acquisition transactions and related post-acquisition reorganizations.

It should also be noted that no distinction in treatment has ever been intended as a function of whether the seller was a resident rather than a non-resident. This is reflected not only by the fact that the Main Rule only applies to a non-resident seller that is not dealing at arm's length with the purchaser corporation – and thus does not apply where a non-resident seller is dealing at arm's length with the purchaser corporation – but also in the Explanatory Notes released in relation to amendments to the Main Rule in 1984 introducing a technical exclusion for situations in which the purchaser corporation is technically deemed not to be dealing at arm's length with a non-resident seller by virtue of paragraph 251(5)(b):

Section 212.1 of the Act ensures that non-residents cannot use non-arm's length reorganizations of their Canadian corporations to convert dividend distributions that

¹¹ *Ibid.*

would be subject to non-resident withholding tax under Part XIII of the Act into tax-free capital gains.

In corporate takeovers the acquiring corporation will usually have a right to purchase the shares of a target corporation before the actual acquisition occurs. Under paragraph 251(5)(b) of the Act, a person who holds a right to acquire, or to control the voting rights of, shares of a corporation is treated as owning the shares. This may result in the acquiring corporation being treated as controlling the target corporation and therefore as not dealing at arm's length with those persons from whom it is purchasing the shares. It is inappropriate for section 212.1 to be applied to the sale of shares of a Canadian corporation by a non-resident to a purchaser with whom he is deemed not to be dealing at arm's length simply because of the existence of such a right. The amendment to subsection 212.1(1) of the Act, applicable to dispositions of shares after April 10, 1978, corrects this problem.

Once again, these comments reflect the basic architecture of the “major reform” that was introduced under the 1977 Budget – namely, “distinguishing a normal sale from a sale which is part of a contrived scheme”. Simply stated, that “major reform” permitted *bona fide* acquisition transactions and related post-acquisition reorganizations, while preventing non-residents seeking to extract surplus accumulated during their holding periods from using “non-arm's length reorganizations of their Canadian corporations to convert dividend distributions ... into tax-free capital gains”.

Against this background, we would also offer our understanding of the “control” requirement incorporated in subsection 212.1(4). As noted above, and as reflected in Budget 2016, the Exception applies “in respect of a disposition by a non-resident corporation of shares of a subject corporation to a purchaser corporation that immediately before the disposition controlled the non-resident corporation”. What this language does not elucidate are the circumstances in which such “control” is expected to arise or how long it is expected to be present. However, given the context, and as acknowledged in Budget 2016 (i.e., “An exception to this anti-surplus-stripping rule ... applies where a Canadian corporation ... acquires shares of a non-resident corporation that itself owns shares of a Canadian corporation”), it is reasonable to posit that the control of the non-resident corporation in question should not be considered to be artificial for the purposes of the Exception where such control has been acquired by the taxpayer (or a person related to the taxpayer) in a *bona fide* acquisition from an arm's length party. Moreover, given that the Exception is intended, at a minimum, to facilitate a post-acquisition reorganization (in the words of Budget 2016, whereby “the non-resident disposes of shares of the lower-tier Canadian corporation to the Canadian purchaser corporation in order to unwind the sandwich structure”),¹² it cannot reasonably be posited that there is any systemic expectation that such control should be present for any significant period of time. On the contrary, it would be

¹² See the discussion below under Other Considerations. In particular, with reference to a “sandwich” created by a historical shareholder group, it is our view that no mischief should be considered to arise where the PUC of the top-tier Canadian-resident corporation does not reflect (and has not been increased by) any amount of surplus accumulated during the historical shareholder group's holding period.

reasonable to posit that the systemic expectation would be that the “sandwich” might well be unwound as soon as reasonably practicable after the acquisition of control – possibly even on the same day as control was acquired.

In our view, it is also important to demystify the absence of a “hard basis” rule in section 212.1, compared with section 84.1. In brief, given the context and purpose of the Exception in subsection 212.1(4), which contemplates a *bona fide* acquisition of control of the non-resident corporation followed by a post-acquisition reorganization implemented in order to unwind the sandwich structure, it seems to us to be unreasonable to posit that abusive tax avoidance arises simply because section 212.1 does not contain a “hard basis” rule.

The purpose of the “hard basis” rule in section 84.1 is to permit PUC to be increased through non-arm’s length transactions in certain circumstances. In a very general sense, that is also the purpose of the Exception in subsection 212.1(4), given that the contemplated post-acquisition reorganization would, by definition, take place among non-arm’s length parties. In that context, however, the taxpayer group would have arm’s length basis in the shares of the acquired non-resident corporation (i.e., basis that arises from a *bona fide* arm’s length acquisition – not basis that simply arises from a non-arm’s length transaction). This is important because the “hard basis” rule in section 84.1 is not really there to permit PUC to be increased to the extent of arm’s length basis, but rather to permit PUC to be increased to the extent of non-arm’s length basis where it arises from a disposition that is not sheltered by V-Day basis or the capital gains exemption enjoyed by a non-arm’s length party.

This is similar to the rule that was proposed to be added to section 212.1 by the 1998 Budget, and parallel to the related changes made to section 128.1(1), introducing paragraph 128.1(c.1). The 1998 proposed amendment to section 212.1 would have permitted PUC to be increased to the extent of non-arm’s length basis where the same arises from a disposition that is not sheltered by a treaty exemption. Like the “hard basis” rule in section 84.1, this had nothing to do with basis arising from a *bona fide* arm’s length acquisition.

The reason for this distinction seems obvious¹³ in light of the fundamental definitional issue posited in the Carter Commission Report – namely, “distinguishing a normal sale from a sale which is part of a contrived scheme”. If PUC could be increased to the extent of any and all basis, then it would be easy for parties to create basis – and thus to create PUC – through non-arm’s transactions, relying on V-Day value, the capital gains exemption or a treaty exemption.¹⁴ That would allow them to implement a “contrived scheme” to extract surplus accumulated during their holding period without the payment of any tax at the shareholder level. However, a *bona fide* arm’s length acquisition – and the basis that results from a *bona fide* arm’s length acquisition – has nothing to do with any such “contrived scheme”.

¹³ Although it is not clear why the proposed amendment to section 212.1 was never implemented. While we understand there was concern that it could have been manipulated, it could have been restructured to address that concern and reintroduced.

¹⁴ With the narrowing of the definition of taxable Canadian property, in many cases a treaty exemption may no longer be claimed.

It is for this reason that basis that results from a *bona fide* arm's length acquisition is not restricted under the "hard basis" rule in section 84.1 regardless of whether the seller paid any tax or relied on V-Day value or a capital gains exemption in respect of that disposition. That is simply irrelevant to the "hard basis" rule in section 84.1 because, as noted, that rule is not really there to permit PUC to be increased to the extent of arm's length basis, but rather to permit PUC to be increased to the extent of non-arm's length basis where the same arises from a disposition that is not sheltered by V-Day basis or the capital gains exemption enjoyed by a non-arm's length party.

That is, the underlying rationale of the "hard basis" rule is to permit PUC to be increased through what might otherwise be viewed as an offensive "contrived scheme", as long as the non-arm's length basis arises from taxable transactions.¹⁵ In contrast, where basis (translated into PUC) results from a *bona fide* arm's length acquisition, there is no offensive "contrived scheme" and thus no need for a special rule testing whether the seller was taxable in respect of the disposition. Likewise, there is no offensive "contrived scheme" for the purposes of section 212.1 where there has been a *bona fide* acquisition of control of the non-resident corporation. The Exception in subsection 212.1(4) is designed to permit the non-arm's length transactions that must necessarily occur as part of the contemplated post-acquisition reorganization implemented in order to unwind the sandwich structure. In that context, a treaty exemption might well be claimed in respect of the disposition by the non-resident corporation to its controlling Canadian-resident shareholder as part of the post-acquisition reorganization, since the post-acquisition reorganization would not be expected to be taxable to the purchaser group.¹⁶

On this basis, as noted above, it seems to us to be unreasonable to posit that abusive tax avoidance arises simply because subsection 212.1 does not contain a "hard basis" rule. Section 212.1 contains the Exception in 212.1(4), which clearly contemplates a post-acquisition reorganization that is implemented in relation to a *bona fide* arm's length acquisition of the control of the relevant non-resident corporation.

Appendix A hereto sets out additional and more detailed discussion of the legislative and policy history of section 212.1, as well as the development of and the relationship of this provision to other surplus stripping regimes in the Act, including sections 84.1, 128.1, 212.2 and 212.3.

Objective Evaluation of Tax Base Impact Considerations

There are several practical examples that may be considered in evaluating the tax base and thus tax policy considerations related to distinguishing between purchaser corporations that have, and those

¹⁵ In its historical context, there may also be other circumstances in which section 84.1 is not intended to block PUC from being increased despite the existence of non-arm's length transactions – such as in the context of *bona fide* inter-generational transfers. .

¹⁶ Since the non-resident corporation would become a foreign affiliate of its controlling Canadian-resident shareholder, "foreign accrual property income" could otherwise arise from the disposition by the non-resident corporation to its controlling Canadian-resident shareholder as part of the post-acquisition reorganization, but that too is displaced by the "carve-out" rule in paragraph 95(2)(f.1), further ensuring that the post-acquisition reorganization would not be taxable to the purchaser group.

that do not have, non-arm’s length non-resident shareholders. The analysis below demonstrates objectively that there is no difference between the tax base implications in the situation where the Canadian purchaser corporation has non-resident shareholders compared to where the Canadian purchaser corporation has only Canadian-resident shareholders. Therefore, it demonstrates objectively that it could not have been the intention of the legislature to restrict the application of the Exception in subsection 212.1(4) to circumstances in which the Canadian purchaser corporation does not have non-arm’s length non-resident shareholders.

Direct Acquisition of Canadian Target

Since the “major reform” introduced under the 1977 Budget, it has become typical for non-resident purchasers of Canadian-resident target corporations to use a freshly capitalized Canadian-resident acquisition company to purchase the Canadian target, in order to eliminate any historical PUC deficiency in the shares of the Canadian target.¹⁷ This has been described as “Tax 101”.¹⁸

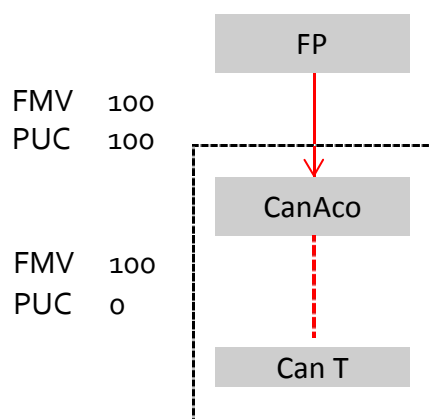

In this example, there is a historical PUC deficiency in the shares of the Canadian-resident target equal to \$100, being the difference between its fair market value (“FMV”) and the historical PUC of its shares. This historical PUC deficiency is eliminated through the use of a freshly capitalized acquisition

¹⁷ This approach is also used in order to access the rule in paragraph 88(1)(d) that permits a “step-up” in the adjusted cost base of the Canadian target’s qualifying capital property – which dovetails with the automatic “carve-out” rule for directly or indirectly acquired foreign affiliates under paragraph 95(2)(f.1), applied together with the definition of “designated acquired corporation” in subsection 95(1). This “reset” approach for *bona fide* acquisition transactions is reflected in many of the rules in the Act, including those in section 111 as well as the foreign affiliate surplus “reset” rules in Regulations 5907(5.2) and (5.4), the latter of which is intended to dovetail with paragraph 88(1)(d).

¹⁸ See *Collins & Aikman Products Co. et al v The Queen*, 2009 TCC 299; 2009 DTC 1179, paragraph 88: “Non-residents holding their Canadian operating companies through a Canadian holding company is pretty much standard operating procedure. It is fair to say that not to do so is the exception. This is Tax 101.” This decision was affirmed in *The Queen v Collins & Aikman Canada Inc. et al*, 2010 FCA 251; 2010 DTC 5164.

company.¹⁹ There is no suggestion – whether in Budget 2016 or otherwise – that this results in abusive tax avoidance.²⁰

¹⁹ There is no PUC deficiency in the shares of the freshly capitalized acquisition company because their FMV is equal to their PUC, and the historical PUC deficiency in the shares of the Canadian-resident target becomes irrelevant because the shares are not held by a non-resident or the shares are eliminated on a post-acquisition winding-up into or amalgamation with the acquisition company.

²⁰ See also the discussion below in relation to subsections 212.3(7) and (9).

Indirect Acquisition of Canadian Target

Exactly the same result arises where a freshly capitalized Canadian acquisition company is used to acquire a non-resident corporation that in turn holds an underlying Canadian-resident corporation with a historical PUC deficiency.

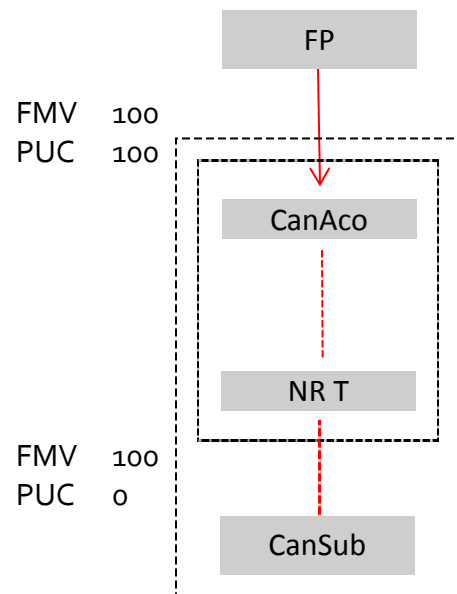

In this example, again there is a historical PUC deficiency in the shares of the Canadian-resident sub-target (i.e., “CanSub”) equal to \$100, being the difference between the FMV, and the historical PUC, of its shares. This historical PUC deficiency is eliminated through the use of a freshly capitalized acquisition company.²¹

Budget 2016 is ambiguous with respect to whether this is considered to result in abusive tax avoidance. On the one hand, Budget 2016 states that the Exception “applies where a Canadian corporation ...

²¹ Again, there is no PUC deficiency in the shares of the freshly capitalized acquisition company because their FMV is equal to their PUC, and the historical PUC deficiency in the shares of CanSub becomes irrelevant because the shares are not held by a non-resident or the shares are eliminated on a post-acquisition winding-up into or amalgamation with the acquisition company, after the shares of CanSub are first directly acquired by the acquisition company from the non-resident target on the post-acquisition winding-up of the non-resident target or otherwise.

The acquisition of the non-resident target by the freshly capitalized acquisition company results in the application of section 212.3 (but not section 212.2) because the non-resident target becomes a foreign affiliate of the acquisition company. However, no deemed dividend arises because of the PUC “offset” rule in subsection 212.3(7). On the winding-up of the non-resident target, the PUC of the freshly capitalized acquisition company is “reinstated” under subsection 212.3(9). This is an appropriate result under section 212.3 and more generally because the series of transactions reflects a *bona fide* indirect acquisition of a Canadian target, and not a situation truly involving “foreign affiliate dumping”, since there is no continuing interest in a foreign affiliate held through a corporation resident in Canada that is controlled by a non-resident corporation.

acquires shares of a non-resident corporation that itself owns shares of a Canadian corporation". On the other hand, Budget 2016 proposes to restrict the Exception such that it would no longer apply where the Canadian-resident acquiring corporation has even a single non-arm's length non-resident shareholder.²² Thus, instead of "distinguishing a normal sale from a sale which is part of a contrived scheme" in accordance with the principles of the "major reform" introduced under the 1977 Budget, Budget 2016 distinguishes between resident and non-resident purchasers, which is a distinction (that was present under the former "designated surplus" regime) that the "major reform" introduced under the 1977 Budget was designed to eliminate.

Indirect Acquisition by Canadian-Resident Parent

The final example demonstrates that there is no objective basis on which to distinguish between *bona fide* resident and non-resident purchasers in terms of the tax base implications and considerations that would seem to be relevant in this regard.

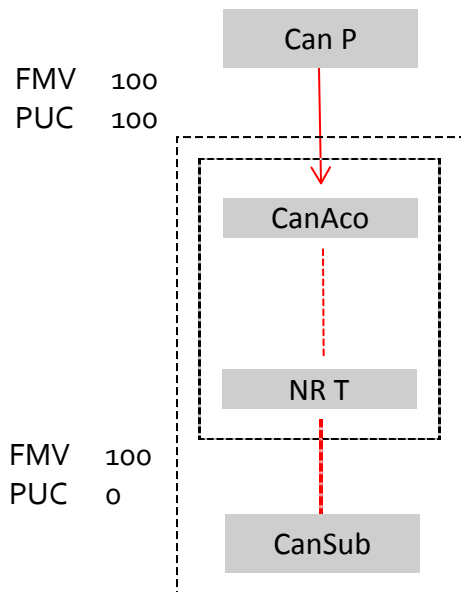

The only significant difference between this example and the previous one is that the shareholder of the freshly capitalized Canadian-resident acquisition company is a Canadian parent corporation rather than a non-resident parent corporation.

²² Interestingly, there is no restriction even where all the shares of the Canadian-resident acquiring corporation are held by non-residents, provided that none of these non-residents is not dealing at arm's length with the Canadian-resident acquiring corporation.

Again there is a historical PUC deficiency in the shares of CanSub equal to \$100, being the difference between its FMV and the historical PUC of its shares, and again this historical PUC deficiency is eliminated through the use of a freshly capitalized acquisition company.²³

Two additional points should also be noted. If the Canadian parent corporation raises the funds to finance the acquisition through a fresh issuance of equity, there would be no separate PUC deficiency at the level of the shares of the Canadian parent corporation. Thus, the aggregate PUC deficiency at the level of the Canadian parent corporation and the level of CanSub before the acquisition transaction would be \$100, and after the acquisition transaction and post-acquisition reorganization it would be *nil*, such that the acquisition transaction and post-acquisition reorganization would result in an aggregate PUC deficiency reduction of \$100. Similarly, if the Canadian parent corporation uses its retained earnings rather than freshly issued equity to fund the acquisition, there would be a separate PUC deficiency at the level of the shares of the Canadian parent corporation of \$100 (i.e., the difference between their FMV attributable to undistributed retained earnings of \$100 and their PUC of *nil*), such that the aggregate PUC deficiency at the level of the Canadian parent corporation and the level of CanSub before the acquisition transaction would be \$200. However, but after the acquisition transaction and post-acquisition reorganization it would be \$100 (being the continuing PUC deficiency at the level of the Canadian parent corporation), such that the acquisition transaction and post-acquisition reorganization would result in an aggregate PUC deficiency reduction of \$100.

This is exactly the same as the aggregate PUC deficiency reduction where:

- the Canadian parent corporation funds the acquisition through freshly issued equity
- a non-resident parent corporation uses a freshly capitalized Canadian-resident acquisition company to directly acquire a Canadian-resident target
- a non-resident parent corporation uses a freshly capitalized Canadian-resident acquisition company to indirectly acquire a Canadian-resident corporation through a direct acquisition of a non-resident target.

This demonstrates that no distinction should be made between resident and non-resident purchasers on the basis that “the surplus remains in Canada” where the purchaser is a resident rather than a non-resident.²⁴ The question is not about the location of the surplus – or of the underlying assets – since in

²³ Again, there is no PUC deficiency in the shares of the freshly capitalized acquisition company because their FMV is equal to their PUC, and the historical PUC deficiency in the shares of CanSub becomes irrelevant because they are not held by a non-resident or gets eliminated on a post-acquisition winding-up into or amalgamation with the acquisition company, after the shares of CanSub are first directly acquired by the acquisition company from the non-resident target on the post-acquisition winding-up of the non-resident target or otherwise.

In this case, the acquisition of the non-resident target by the freshly capitalized acquisition company does not result in the application of section 212.3 because the acquisition company is not controlled by a non-resident corporation.

²⁴ This proposition was asserted by the Crown in *Univar*, and accepted by the Court in paragraph 99 of the Reasons for Judgment.

all cases the underlying assets remain in Canada, at least until the time of any subsequent distribution. The question is about the elimination of the surplus – or of the PUC deficiency – and in all cases exactly the same amount of surplus is eliminated or PUC deficiency reduced – equal to any historical PUC deficiency in the shares of the directly or indirectly acquired Canadian-resident target corporation.

Where the purchaser is a Canadian-resident parent corporation, a subsequent distribution would not normally result in any shareholder-level deemed dividend where the parent corporation funded the acquisition with fresh equity regardless of whether that distribution is made to resident or non-resident shareholders. A subsequent distribution by a Canadian-resident parent corporation would result in a shareholder-level dividend or deemed dividend, both to resident and non-resident shareholders, not only to the extent of the Canadian-resident parent's own pre-existing or historical PUC deficiency (i.e., where it funded the acquisition using its retained earnings rather than fresh equity) but without any connection whatsoever to the amount of any historical PUC deficiency in the shares of the directly or indirectly acquired Canadian-resident corporation.

Where the purchaser is a non-resident parent corporation using a freshly capitalized Canadian-resident acquisition company, a subsequent distribution by the freshly capitalized Canadian-resident acquisition company would remove assets (or at least net assets) from Canada. However, that is equally true in the context of a distribution subsequent to a direct acquisition of a Canadian-resident target (as in the first example above) and in the context of an indirect acquisition of a Canadian-resident target through a direct acquisition of a non-resident target (as in the second example above). This is appropriate in both cases because in both cases the non-resident receiving the distribution is simply recovering its tax-paid funds invested in Canada rather than extracting any post-investment income it has earned without incurring Part XIII withholding tax. We would also emphasize that, as noted above, a subsequent distribution by a Canadian-resident parent corporation could be made to non-resident shareholders – without the imposition of Part XIII withholding tax where the parent corporation has funded the acquisition with fresh equity. Even where the Canadian parent corporation has funded the acquisition with retained earnings, a subsequent distribution by it to non-residents would be subject to Part XIII withholding tax only to the extent of the parent's own pre-existing PUC deficiency. Thus, the presence or absence of Part XIII withholding tax in respect of a subsequent distribution to non-residents will not depend on the amount of any historical PUC deficiency in the shares of the directly or indirectly acquired Canadian-resident corporation.

Accordingly, there is no objective basis to distinguish between *bona fide* resident and non-resident purchasers, or between direct acquisitions and indirect acquisitions, in terms of the tax base implications and considerations that would seem to be relevant in this regard.

Finally, we note that there is considerable additional support for the proposition that the Act contemplates post-acquisition transactions to reset tax attributes to acquisition date values, even if undertaken well after the acquisition, in the rules relating to paragraph 88(1)(d). This parallel to subsection 212.1(4) is quite interesting:

- acquisition of control is contemplated in both cases

- tax attribute reset is contemplated in both cases (ACB vs PUC, and we would add foreign affiliate "shadow ACB" under paragraph 95(2)(f.1) and surplus under Regulations 5905(5.2) and 5.4))
- tax attribute reset must at times be effected through a transaction (i.e., it is not an automatic result of the acquisition in the case of domestic attributes but is automatic for foreign affiliate attributes, which include surplus accounts, being a direct measure of surplus, whereas PUC is an indirect measure of surplus)
- the type of transaction contemplated by both is a post-acquisition distribution of shares of an underlying subsidiary from below the target, and
- an ACB reset transaction can be undertaken years after the acquisition of control but must be limited to value as at the acquisition of control date.

Framed that way, it seems very difficult to accept that there is something suspect about a post-acquisition transaction being used to reset tax attributes, such as cross-border PUC, assuming that the acquisition date value is respected.

That leaves only one issue – being whether there is valid a distinction between foreign parents and Canadian parents. There is no such distinction for the purposes of the paragraph 88(1)(d) bump, and rulings have confirmed that. There is no such distinction for PUC in subsection 212.1(4), and none should be added because a distinction cannot be justified based on the objective analysis of numerical examples in this submission.

Recommendation:

We recommend that the proposed restriction to the Exception be restructured so that it would align with “distinguishing a normal sale from a sale which is part of a contrived scheme”, and does not distinguish between *bona fide* non-resident purchasers and *bona fide* Canadian-resident purchasers, in accordance with the principles reflected in the 1977 Budget and the original and continuing underlying rationale of subsection 212.1(1).

This might be implemented in a variety of ways – including by restricting the application of subsection 212.1(4) to situations in which there has been a *bona fide* arm’s length acquisition of control of the relevant Canadian-resident corporation, along the lines of the definition of “designated acquired corporation” in subsection 95(1), coupled with a mechanism that would limit the amount by which the PUC of its shares can be increased to the portion of the arm’s length consideration paid in relation to the direct acquisition of the shares of the relevant non-resident corporation that can reasonably be considered to be attributable to the indirect acquisition of the shares of the relevant Canadian-resident corporation, along the lines of the indirect consideration attribution rule in subsection 212.3(2).

Other Considerations

Aside from the more fundamental scope and policy considerations noted above, the proposed restriction to the Exception under Budget 2016 also raises a number of important narrower concerns.

Lack of PUC Offset and Similar Considerations

In contrast to subsection 212.1(1) and the “foreign affiliate dumping” rules in section 212.3, there is no mechanism in relation to the proposed restriction to subsection 212.1(4) that would mitigate its impact where the Canadian-resident purchaser corporation either has sufficient PUC to absorb the PUC deficiency reduction in respect of the shares of the indirectly acquired Canadian-resident corporation or where the relevant transactions have not resulted in any increase in the cross-border PUC of the Canadian-resident purchaser corporation.

Under subsection 212.1(1), where the consideration given by a Canadian-resident purchaser corporation in exchange for shares of a directly acquired Canadian-resident corporation consists of shares of the purchaser corporation, the PUC of the shares of the purchaser corporation is reduced before any deemed dividend can arise. Similarly, under subsections 212.3(2) or (7), the PUC of the purchaser corporation is reduced before any deemed dividend can arise. In contrast, in the context of an indirect acquisition followed by a post-acquisition reorganization resulting in exactly the same configuration as a direct acquisition, there would be an immediate deemed dividend at the time of the post-acquisition reorganization regardless of the amount of the PUC of the purchaser corporation.

Moreover, under subsection 212.1(1), where the consideration given by a Canadian-resident purchaser corporation in exchange for shares of a directly acquired Canadian-resident corporation consists of shares in the capital stock of the purchaser corporation, no deemed dividend arises where the PUC of the shares of the purchaser corporation is not increased by an amount exceeding the PUC of the acquired corporation. In contrast, in the context of an indirect acquisition followed by a post-acquisition reorganization resulting in exactly the same configuration as a direct acquisition, there would be an immediate deemed dividend at the time of the post-acquisition reorganization regardless of the amount, if any, by which the PUC of the purchaser corporation was increased as a result of the acquisition.

Thus, the consequences of the proposed restriction to the Exception are not consistent with the policy considerations reflected in subsection 212.1(1) in relation to direct acquisitions or those reflected in subsection 212.3 in relation to indirect acquisitions.

Recommendation:

We recommend that a mechanism be introduced into section 212.1 that would align the consequences of the application of subsection 212.1(1) in the context of an indirect acquisition and post-acquisition reorganization with those in the context of a direct acquisition. These consequences should also be aligned and coordinated with the application of subsections 212.3(2) and (7) and with the PUC “reinstatement” rule in subsection 212.3(9).

Withholding Tax Rate

Under subsection 212.3(3), provision is made (the “dividend substitution election”) to permit any deemed dividend that survives the “offset” mechanism to be taxed at an appropriate rate, in light of an applicable income tax convention. In contrast, under section 212.1(1), the deemed dividend is necessarily deemed paid by the purchaser corporation to the non-resident corporation. Where the selling non-resident corporation is a subsidiary of the purchaser corporation, the treaty-reduced rate of withholding tax would typically be 15%, rather than the 1 rate of 5% that normally would apply if the underlying Canadian-resident corporation that is held by the non-resident corporation were deemed to pay a dividend to the non-resident selling corporation.

Recommendation:

We therefore recommend that a similar “dividend substitution election” be introduced into subsection 212.1(1) that would permit the selling non-resident corporation to elect that any deemed dividend be deemed to have been paid to it by the underlying Canadian-resident corporation rather than by the purchaser corporation.

Multiple Taxation

There can be circumstances in which a Canadian-resident corporation holds a non-resident corporation which in turn holds another Canadian-resident corporation which in turn holds yet another non-resident corporation that in turn holds yet another Canadian-resident corporation. Such a “double sandwich” can arise because of multiple acquisitions or for other reasons. However, it would be unfair in our view for multiple layers of Part XIII withholding tax to arise where there is a vertical chain of corporations that ultimately reflects only a single ultimate PUC deficiency.

Recommendation:

We recommend that provision be made to mitigate the possibility of multiple layers of Part XIII withholding tax where there is a vertical chain of corporations that ultimately reflects only a single ultimate PUC deficiency.

Non-Arm’s Length Non-Residents versus Controlling Non-Resident Corporations

Unlike under section 212.3, which only applies to a corporation resident in Canada that is controlled by a non-resident corporation, the proposed restriction to subsection 212.1(4) would require only that the Canadian-resident purchaser corporation have a single share held by a non-arm’s length non-resident. These two standards are inconsistent in important respects.

First, this would result in the displacement of subsection 212.1(4) where a non-arm’s length individual holds a single share of the Canadian-resident purchaser corporation. This can arise, for example, where a single member of an otherwise Canadian-resident family which owns the Canadian-resident purchaser corporation happens to move to a different country while retaining his or her interest in the Canadian-resident purchaser corporation.

Moreover, where a Canadian-resident purchaser corporation is held by a partnership – for example, a private equity fund – which is not otherwise a “designated partnership” as defined for purposes of subsection 212.1(1) because the majority of the members of the partnership are Canadian residents, subsection 212.1(4) could be displaced if the general partner is a non-resident corporation or if the general partner is a Canadian-resident corporation that has a non-arm’s length non-resident shareholder – depending on the interpretation of the proposed phrase “owns, directly or indirectly, shares of the capital stock of the purchaser corporation”, as well as other interpretive considerations that would be relevant in the context of a provision that includes this phrase alongside references to a “designated partnership”.

Recommendations:

We recommend that the proposed restriction to subsection 212.1(4) be restructured so that it would be aligned with section 212.3 in this regard – that is, that subsection 212.1(4) would only be displaced where the Canadian-resident purchaser corporation is controlled by a non-resident corporation.

A related consideration is that subsection 212.3(15) deems a corporation resident in Canada to not be controlled by a non-resident corporation where the latter is in turn ultimately controlled by Canadian residents. A similar feature would seem to be appropriate in the context of the proposed restriction to subsection 212.1(4).

Series Issues

Section 212.3 has been designed to be sensitive to situations in which the breadth of the “series of transactions” notion would cause technical application in situations that do not come within the intended policy scope of this regime. One example is the changes made to paragraph 212.3(1)(b) for situations in which a foreign affiliate investment occurs as part of a series of transactions which includes a moment of control by a non-resident corporation but it is before the investment time or even after in certain circumstances.²⁵ Another example is the changes made to the reorganization rules in paragraph 212.3(18)(a), among other provisions, to permit certain post-acquisition reorganizations.²⁶

In contrast, because the proposed restriction to subsection 212.1(4) includes ownership by a non-arm’s length non-resident “as part of a transaction or event or series of transactions or events that includes the disposition”, this provision would be displaced even where the purchaser corporation is owned exclusively by Canadian residents if the purchaser corporation was acquired as part of the series from a non-resident seller. Likewise, if a purchaser corporation is owned exclusively by Canadian-residents at the time that subsection 212.1(4) would otherwise apply, but is subsequently sold to non-residents as part of the same series, subsection 212.1(4) would be displaced. In both cases, the economic benefit of

²⁵ See S.C. 2014, c. 39, s. 65(1), applicable in general in respect of transactions and events that occur after March 28, 2012.

²⁶ See 2014, c. 39, s. 65(16), applicable in general in respect of transactions and events that occur after March 28, 2012.

the application of subsection 212.1(4) would be withdrawn from interests that are exclusively Canadian, simply because of the breadth of “series of transactions”.

We also note that the problem here is even broader than it was in the context of section 212.3 before the changes noted above were introduced because of the potential for subsection 212.1(4) to be displaced because of the presence of a single share held by a non-arm’s length non-resident. Thus, for example, if the purchaser corporation were to redeem the share held by a non-arm’s length non-resident and then proceed to acquire a non-resident target corporation followed by a post-acquisition reorganization, subsection 212.1(4) would be displaced if these events are considered to occur as part of the same series. A similar result may occur if one or more resident members of a family that owns controls a corporation acquires the shares of the family member who ceased to be resident prior to the acquisition of a non-resident target corporation.

A related point is that it seems inappropriate to us that the application of subsection 212.1(4) would be displaced completely regardless of the percentage of the economic benefit of its application that would be enjoyed by a non-arm’s length non-resident.

Recommendation:

We recommend that provision be made for circumstances in which there is a change of share ownership as part of the relevant series of transactions where the economic benefit of the application of subsection 212.1(4) is enjoyed by Canadian residents or, in any event, is not enjoyed by a non-arm’s length non-residents.

We also recommend that a mechanism be introduced that would limit the impact of subsection 212.1(1) to the extent that the economic benefit of the application of subsection 212.1(4) is enjoyed by persons other than non-arm’s length non-residents.

Most Closely Connected Test

In contrast to section 212.3, the proposed restriction to subsection 212.1(4) does not reflect the possibility that the business activities of the directly acquired non-resident target corporation and its underlying indirectly acquired Canadian-resident corporation may be most closely connected to the business activities of a Canadian-resident purchaser corporation that has a non-arm’s length non-resident shareholder. This unfairly discriminates against Canadian-resident purchaser corporations in situations where they acquire non-resident target corporations with underlying Canadian-resident subsidiaries.

Recommendation:

We recommend that a mechanism be introduced into subsection 212.1(4) that would permit it to apply in situations in which the business activities of an underlying indirectly acquired Canadian-resident corporation are most closely connected to the business activities of a Canadian-resident purchaser corporation that has a non-arm’s length non-resident shareholder.

APPENDIX TO JOINT COMMITTEE SUBMISSION

HISTORY OF SUBSECTION 212.1(4)

Subsection 212.1(1) provides a so-called anti-“dividend-stripping” or “surplus stripping” rule aimed at what can be described as constructive distributions where a non-resident disposes of shares of a corporation resident in Canada to another corporation resident in Canada with which it is not dealing at arm’s length. It reads:

(1) If a non-resident person, a designated partnership or a non-resident-owned investment corporation (in this section referred to as the "non-resident person") disposes of shares (in this section referred to as the "subject shares") of any class of the capital stock of a corporation resident in Canada (in this section referred to as the "subject corporation") to another corporation resident in Canada (in this section referred to as the "purchaser corporation") with which the non-resident person does not (otherwise than because of a right referred to in paragraph 251(5)(b)) deal at arm's length and, immediately after the disposition, the subject corporation is connected (within the meaning that would be assigned by subsection 186(4) if the references in that subsection to "payer corporation" and "particular corporation" were read as "subject corporation" and "purchaser corporation", respectively) with the purchaser corporation,

(a) the amount, if any, by which the fair market value of any consideration (other than any share of the capital stock of the purchaser corporation) received by the non-resident person from the purchaser corporation for the subject shares exceeds the paid-up capital in respect of the subject shares immediately before the disposition shall, for the purposes of this Act, be deemed to be a dividend paid at the time of the disposition by the purchaser corporation to the non-resident person and received at that time by the non-resident person from the purchaser corporation; and

(b) in computing the paid-up capital at any particular time after March 31, 1977 of any particular class of shares of the capital stock of the purchaser corporation, there shall be deducted that proportion of the amount, if any, by which the increase, if any, by virtue of the disposition, in the paid-up capital, computed without reference to this section as it applies to the disposition, in respect of all of the shares of the capital stock of the purchaser corporation exceeds the amount, if any, by which

(i) the paid-up capital in respect of the subject shares immediately before the disposition

exceeds

(ii) the fair market value of the consideration described in paragraph (a),

that the increase, if any, by virtue of the disposition, in the paid-up capital, computed without reference to this section as it applies to the disposition, in respect of the particular class of shares is of the increase, if any, by virtue of the disposition, in the paid-up capital, computed without reference to this section as it applies to the disposition, in respect of all of the issued shares of the capital stock of the purchaser corporation.

The type of tax planning targeted by so-called surplus stripping anti-avoidance provisions such as subsection 212.1(1) has been described as follows:

Surplus stripping is considered to occur when a shareholder takes a shortcut in accessing accumulated surplus of a corporation. This has generally meant choosing to realize the economic value of such surplus

through a transaction characterized as a sale of shares that gives rise to a capital gain, rather than a distribution from the corporation that is taxed as a dividend.¹

This is consistent with the Explanatory Notes to section 212.1, which state that:

Subsection 212.1 [sic] is an anti-avoidance rule designed to prevent the removal of taxable corporate surplus as a tax-free return of capital through a non-arm's length transfer by a non-resident of shares from one Canadian corporation to another Canadian corporation.²

Moreover, the 1984 Explanatory Notes to section 212.1 provide the following comments:

EN November 1984 [S.C. 1984, c. 45 (Bill C-7)] — Section 212.1 of the Act ensures that non-residents cannot use non-arm's length reorganizations of their Canadian corporations to convert dividend distributions that would be subject to non-resident withholding tax under Part XIII of the Act into tax-free capital gains.

In corporate takeovers the acquiring corporation will usually have a right to purchase the shares of a target corporation before the actual acquisition occurs. Under paragraph 251(5)(b) of the Act, a person who holds a right to acquire, or to control the voting rights of, shares of a corporation is treated as owning the shares. This may result in the acquiring corporation being treated as controlling the target corporation and therefore as not dealing at arm's length with those persons from whom it is purchasing the shares. It is inappropriate for section 212.1 to be applied to the sale of shares of a Canadian corporation by a non-resident to a purchaser with whom he is deemed not to be dealing at arm's length simply because of the existence of such a right. The amendment to subsection 212.1(1) of the Act, applicable to dispositions of shares after April 10, 1978, corrects this problem.

This comment from the Department of Finance contrasts internal reorganizations implemented to convert dividend distributions with situations where an actual arm's length corporate takeover has occurred.

Subsection 212.1(4) provides an important exception to the application of subsection 212.1(1) as follows:

(4) Notwithstanding subsection 212.1(1), this section does not apply in respect of a disposition by a non-resident corporation of shares of a subject corporation to a purchaser corporation that immediately before the disposition controlled the non-resident corporation.

Subsection 212.1(4) was introduced into the Act in 1978, one year following the enactment of section 212.1, without explanatory notes. In our view, the fairly obvious purpose of this provision is to preclude the application of subsection 212.1(1) in circumstances where a Canadian-resident corporation has been acquired "indirectly" through the acquisition of a non-resident corporation that held the shares of the Canadian-resident corporation. This provision reflects a Parliamentary acknowledgement that it is not feasible in all circumstances for a purchaser to structure an acquisition of a Canadian-resident corporation in the usual manner – that is, directly – and that a less than ideal structure may result from the acquisition transaction, which will have to be restructured in a post-acquisition reorganization. This provision also reflects an acknowledgement by Parliament that the post-acquisition elimination of any

¹ *McNichol et al v. The Queen*, 97 DTC 11 (TCC), citing H.H. Stikeman and R. Couzin, "Surplus Stripping" (1995), 43 Can. Tax J. No. 5 1844 at 1858, referring to section 84.1 the domestic context equivalent to section 212.1.

² *Explanatory Notes to s. 212.1*, S.C. 1999, c.22 (Bill C-72), see also IT-489R.

PUC deficiency on the shares of a Canadian-resident corporation held by an acquired non-resident target corporation should not in itself be regarded as an inappropriate tax consequence. In other words, the purchaser is not forced or expected (because of section 212.1) to “inherit” any PUC deficiency on the shares of a Canadian-resident corporation held by an acquired non-resident target corporation.

It is also interesting to note that a disposition of the shares of a non-resident corporation that holds shares of a Canadian-resident subsidiary would be unlikely to be taxable in Canada with respect to any accrued capital gain that a non-resident seller would have thereby realized.³ Thus, given the types of transactions seemingly contemplated by subsection 212.1(4), the consequences provided for by the rule are not premised on the payment of tax in Canada by the seller on any corresponding capital gain.⁴ Moreover, although any accrued capital gain on the shares of the Canadian-resident corporation held by the acquired non-resident corporation would remain intact, and its taxability or non-taxability on the post-acquisition reorganization would be a matter that is separate from the elimination of the PUC deficiency, this too is unlikely to be taxable to the acquiring group after the acquisition either directly or indirectly.⁵

1. Elimination of the “Designated Surplus” Rules

a) Historical Background

The “designated surplus” rules⁶ were introduced into the Act in the 1950s and were designed to levy a tax on the corporate *purchaser* of the shares of another Canadian corporation to offset the fact that the vendor shareholders were able to dispose of their shares for a tax-free capital gain in circumstances where part of the gain was related to the accumulation of surplus in the target corporation. These accumulated surpluses would have been taxable if paid-out directly to selling shareholders as dividend income. At the time, taxpayers were transferring shares of one company resident in Canada to a second followed by a tax-free transfer of assets to the purchaser by way of an inter-corporate dividend. It was the first attempt by the Department of Finance to stop surplus stripping. One must bear in mind that, at the time, capital gains were not subject to taxation in Canada and only became subject to taxation in 1972.

Generally, the “designated surplus” rules were applicable in circumstances where the shares of the Canadian corporation were purchased by a Canadian corporation. The rules required the corporate shareholder to include in its taxable income, dividends which were paid-out of the surplus of the acquired corporation which was on hand at the time the shares of the corporation were acquired. The surplus on hand at the end of the taxation year prior to the acquisition of control became “designated

³ Unless the shares derive their value principally from Canadian real property, and subject to the application of a relevant income tax convention.

⁴ This is also true in the context of the use of a freshly capitalized acquisition company to implement a direct acquisition of a Canadian-resident target corporation.

⁵ Again, this would depend on whether the shares derive their value principally from Canadian real property, and would be subject to the application of a relevant income tax convention. Moreover, no “foreign accrual property income” (“FAPI”) should arise to be attributed to the Canadian acquirer because any capital gains accrued before the arm’s length acquisition would normally be excluded by virtue of the “carve-out” rule in paragraph 95(2)(f.1).

⁶ Under former section 105A of the Act.

surplus” and dividends paid-out from these surpluses were subject to tax as business income tax. Over time, the rules were expanded to cover the sale of shares of a Canadian corporation to non-resident corporations, charitable organizations and tax-exempt entities.

In other words, the “designated surplus” rules were an attempt to freeze earnings in a corporation upon an acquisition of control and to prevent their withdrawal as a tax-free inter-corporate dividend. The idea was to prevent individuals from converting taxable dividends into tax-free capital gains by selling a corporation with accumulated earnings to another (Canadian) corporation.

As previously noted, the tax reform of 1972 introduced a tax on capital gains. The tax on dividends paid out of “designated surplus” was reduced to 25 percent from 47%. A shareholder was permitted to recover the paid-up capital of his shares from the corporation on a tax-free basis before being subjected to tax in respect of the surplus of the corporation. The concept of paid-up capital deficiency⁷ (“PUCD”) was introduced to ensure that funds that in certain situations could have been paid to a shareholder as a return of capital were taxed as a dividend. Under these rules, the maximum amount which could be paid to a shareholder as a tax-free return of capital was determined by the “paid-up capital limit” (“PUCL”) of the corporation. If the corporation’s PUC for corporate law purposes exceeded the corresponding amount for tax purposes, the difference was regarded as a PUCD. This excess was subtracted from the corporate PUC to determine the PUCL and only that amount could be distributed on a tax-free basis.

In the Canadian Tax Journal, McDonnell and Richardson briefly described the background of the PUCD rules in the Act:

The new rules for corporate distributions introduced in 1971 with the coming of the new tax reform system had to accomplish a number of objectives. From the Revenue's point of view, it was important that the statutory provisions be sufficiently precise to prevent the distribution of income in the form of capital, and this necessitated the concepts of PUCD and PUCL. On the other hand, it was recognized that corporations in existence at the commencement of a new system which would tax all post-1971 capital gains should be permitted to preserve the non-tax status of capital gains and losses and other amounts accrued to the end of 1971. Thus, the special rules which created a new category of surplus in such corporations known as 1971 capital surplus on hand (1971 CSOH) and which allowed a corporation to make tax-free distributions of such surplus to its shareholders.

In theory, the concepts of PUCD and 1971 CSOH were regarded as being complementary, and for purposes of the calculation of those accounts at the end of a corporation's 1971 taxation year, they were. At that point in time, a corporation had either a PUCD or 1971 CSOH, but not both. As originally drafted, both accounts contemplated that adjustments would be necessary after the end of the 1971 taxation year to give effect to transactions occurring after that time. Obvious cases such as the realization of gains or losses accrued to December 31 1971, and the receipt of other amounts not taxable under the pre-1972 rules, were dealt with, but some situations were missed. It was in this area particularly that problems of various kinds began to appear as the tax reform system became operative. The 1974-1975 amendments attempt to deal with those problems in a number of ways and it is proposed here to deal with the new provisions in four categories. The first is merely a list of what may be called housekeeping changes, that is to say, amendments of a technical nature to existing provisions of paragraphs 89(1)(d) and (1) or amendments in the nature of additions to the paragraphs of essentially a non-controversial nature. In the second category are the changes designed to make the two accounts more complementary. The third group includes changes which are not only new but which also are more consequential in nature. The important amendments here are the

⁷ Under former paragraph 89(1)(iv.1) of the Act.

ones dealing with adjustments to the PUCD and 1971 CSOH calculations where section 85 is used to effect a transfer of qualifying property at an elected amount which is less than the fair market value of such property and on certain share acquisitions by corporations in control situations. Related to the third group are a number of special rules designed to limit the recognition of post-1971 PUCD and 1971 CSOH on the happening of specified transactions in non-arm's length or control situations.⁸

The “designated surplus” and PUCD rules were repealed effective April 1, 1977 due to the maturation of the capital gains regime and the increase in the dividend tax credit subject to certain transitional rules.⁹

In addition, the “designated surplus” rules were also repealed by reason of the introduction of section 84.1 in 1974 to address certain situations in which shares of a Canadian corporation were acquired by another Canadian corporation. This introduction of section 84.1 represented a new era of specific anti-avoidance provisions preventing surplus-stripping. The section as originally enacted created a debt limit where debt issued by the purchasing corporation exceeded the lesser of the paid-up capital of the shares purchased and the PUC of the corporation whose shares were purchased. Repayment of the debt resulted in the payment of a dividend equal to the difference between the amount paid and the debt limit of the corporation with respect to the debt. The section was amended several times to end up in the version we know today. The new section 84.1 is similar in concept in that the rule is designed to prevent the removal of assets from a corporation on the sale of its shares to another corporation in a non-arm's length context. However, certain significant differences were brought to the new rules in that new section 84.1 only applies to the transfer of shares by individuals and trusts resident in Canada whereas the former PUCD and debt limit rules applied to corporations resident in Canada that transferred shares of a corporation to a third corporation in a non-arm's length context.

In 1977, at the same time the Department of Finance proposed to abolish the concepts of “designated surplus” and PUCD, section 212.1 was enacted to deal with similar types of transactions as section 84.1 but in an international context. Because of the changes and because (by virtue of treaty exemptions) the CRA could not rely upon collecting tax from the non-resident in respect of any taxable capital gain arising from the share transfer, the two rules were not structured in exactly the same manner – in particular, section 212.1 did not contain the exception in section 84.1 allowing the PUC of the transferee corporation to be as high as the transferor's cost (so-called “hard basis”) in the shares of the transferred corporation.¹⁰

⁸ T.E. McDonnell & E. J. Richardson, *Through the Looking Glass Darkly: Surplus Distributions and the 1974-75 Amendments*, (1975), vol. 23, no. 3 *Canadian Tax Journal*, 276-314.

⁹ The PUCD rules were repealed but a transitional rule provided in subsection 84.2(1) was enacted and had the effect of reducing the PUC of the shares of the purchasing corporation, thereby maintaining the potential of a deemed dividend on the transfer of funds out of the purchasing corporation as a return of capital. More specifically, new subsection 84.2(1) provided for a reduction of the PUC on April 1, 1977 of shares of any corporation which had a PUCD as of March 31, 1977, created in certain specific circumstances (where subparagraph 89(1)(d)(iv.1) or both subparagraphs 89(1)(d)(iv) and (iv.1) applied).

¹⁰ As discussed below in greater detail, an attempt to introduce such an exception was made in 1998 but was never enacted.

b) Underlying Tax Policy

While introduction of the “designated surplus” and PUCD rules in the 1950s and 1970s demonstrates that the Department of Finance has been concerned with surplus stripping transactions implemented by taxpayers, the “designated surplus” rules were very complex and contained numerous anomalies.

In this regard, certain authors have expressed their views regarding the legislator’s intent regarding the introduction and repeal of the designated surplus rules as follows:

Presumably the government anticipated that the corporate purchaser would discount the price paid for the shares acquired from the vendor and thereby pass the tax burden on to the vendor shareholder. The result may have been appropriate in a non-arm’s length transaction where a shell holding company was incorporated to acquire the shares of an operating company and the same shareholders or family members owned the holding company as previously owned the operating company. However, in an arm’s length transaction, the rationale for designated surplus was more difficult to accept. Most tax practitioners would agree that when a Canadian corporation acquired shares of another Canadian company, little discount was ever made in the purchase price negotiated to reflect the potential of designated surplus. Instead, the purchasing corporation continued to operate the acquired company as a separate entity and limited the transfer of dividend income to the parent to earnings arising after control was acquired. In this way, the tax on designated surplus was effectively postponed, as it now turns out, forever. Furthermore, there were anomalies in the designated surplus rules that eroded designated surplus and the potential existed prior to 1972 to eliminate designated surplus through statutory amalgamation. Designated surplus was not an effective deterrent; it was merely a gnat which forced the corporate purchaser to operate the acquired subsidiary as a separate entity, and thus prevented the consolidation of companies in a corporate group.¹¹

From this quote we understand that in the early and mid-1970s it was apparent to the tax community and the Department of Finance that the “designated surplus” rules were not achieving the result contemplated by the legislator. This is especially true in light of the introduction of a capital gains tax and an increase in the dividend tax credit. As previously noted, the tax burden of the “designated surplus” was nominally borne by the *purchaser* corporation that acquired the shares. In a non-arm’s length context, the result was viewed as appropriate. However, in an arm’s length context, the result was viewed as inappropriate – that is, it was viewed as inappropriate to foist the tax cost on an arm’s length purchaser – particularly where the purchase price for the acquired corporation was not generally being diminished to reflect that cost, and where the effect of the rules was more often to create a barrier to desirable corporate reorganizations.

As described by Stanley E. Edwards at the 1971 Canadian Tax Foundation Conference:

[...] The tax on dividends could be avoided under the present Act by taking advantage of the tax-free capital gain in combination with the exemption for intercorporate dividends. In retrospect, it can readily be seen that the designated surplus provisions were not an appropriate remedy, for a number of reasons. They were ineffective, not only because of technical deficiencies, but also because they did not prevent forward stripping. Subsequent earnings could still be transferred by way of tax-free intercorporate dividends in order to pay off the purchase price for the shares. In any event, the designated surplus provisions were aimed at the wrong person, the purchaser of the shares, rather than the vendor who had presumably avoided the tax.

¹¹ James Palmer, Glen E. Cronkwright, Robert J. Dart, Robert F. Lindsay, “Corporate Distributions and the 1977 Tax Changes” Report of the Proceedings of the Twenty-Ninth Tax Conference, 1977 Conference Report (Toronto: Canadian Tax Foundation), p.282.

This was implicitly acknowledged in 1963 by the enactment of section 138A(1). I doubt that any significant revenue has ever been obtained directly from the tax on dividends out of designated surplus. In some cases the designated surplus provisions have been instrumental in inducing companies to pay tax at a low flat rate under a special provision. More often, they have not resulted in any revenue, but have blocked or interfered with desirable reorganizations and rationalizations of corporate arrangements.

For these reasons, the designated surplus provisions have been very unsatisfactory and troublesome under the present Act. The Carter Report recommended their disappearance and the White Paper didn't mention them. It was assumed, with great relief that upon capital gains becoming taxable, designated surplus would be a thing of the past. It is a terrible shock to see it proposed as a permanent feature under the new system.¹²

The Minister of Finance in 1977, the Hon. Donald S. MacDonald, made reference to the fact that anti-avoidance provisions replacing the designated surplus rules had a narrower scope in his 1977 Budget Plan as follows:

There is a need for simplification of the provisions of the Act dealing with the distribution of corporate surplus. Furthermore, the rules, particularly those relating to designated surplus and deficiencies, often hamper constructive business reorganization and expansion.

The designated surplus provisions will be repealed effective April 1, 1977. At the same time, most of the paid-up capital and debt deficiency rules will also be eliminated and the corporate law concept of paid-up capital will be substituted. In addition, the existing provisions relating to 1971 undistributed income and 1971 capital surplus on hand will be substantially phased out over a transitional period. While the need for rules to prevent surplus stripping is reduced, this need is not entirely eliminated. Therefore, anti-avoidance provisions will remain in the Act but their scope will be very considerably narrowed. Further details of these and related changes are included in the Supplementary Information. (Emphasis added)

While it took the Department of Finance a few more years to amend the rules in a dramatic fashion, the Minister of Finance also acknowledged that the scope of the newly introduced anti-avoidance provisions (i.e., sections 84.1 and 212.1) was intended to be considerably narrowed. In particular, the scope of sections 84.1 and 212.1 was limited to non-arm's length transactions, thereby excluding their application in the context of arm's length acquisitions – thereby terminating the practice of foisting onto an arm's length purchaser the tax cost of a PUC deficiency on the shares of an acquired corporation.

Accordingly, when Parliament decided to repeal the “designated surplus” and PUCD rules in 1977 to replace them in part by new sections 84.1 and 212.1 coupled with the capital gains tax, it deliberately resolved that an arm's length purchaser of shares of a corporation should not inherit their PUC deficiency. Thus, whatever may be made of the “implied exclusion” doctrine in various other contexts, in this context the exclusion was an express one. The introduction of subsection 212.1(4) in 1978 simply brought the treatment of indirect acquisitions into line with the treatment of direct acquisitions – which is not unlike the manner in which paragraphs 88(1)(d) and 95(2)(f.1) bring the treatment of indirect acquisitions into line with the treatment of direct acquisitions.¹³ In so providing, Parliament acknowledges that an arm's length purchaser should not be required to bear the cost of a PUC

¹² Stanley E. Edwards, “Corporations and Shareholders”, Report of the Proceedings of the Twenty-Third Tax Conference, 1971 Conference Report (Toronto: Canadian Tax Foundation), p.128.

¹³ Reference may also be made to Regulations 5905(5.2) and (5.4), among other provisions having a similar inspiration.

deficiency on the shares of a Canadian-resident corporation held by an acquired non-resident target corporation.

2. Differences Between Sections 212.1 and 84.1

As noted above, section 84.1 allows a PUC step-up, in the context of a non-arm's length series of transactions, to the extent of so-called "hard basis", whereas section 212.1 does not.

This difference between the two rules is only directly relevant in the context of a non-arm's length acquisition, not in the context of an arm's length acquisition. This is obvious from the fact that the "hard basis" rule in section 84.1 does not come into play in the context of an arm's length acquisition. In other words, in the context of an arm's length acquisition, neither section 84.1 nor section 212.1 applies, regardless of the vendor's cost base in the shares in question, and regardless of the tax treatment to the vendor of the disposition of those shares. For example, the fact that a vendor may claim the capital gains exemption in respect of the disposition of the shares is simply not relevant in the context of an arm's length acquisition.

In a sense, the function of the "hard basis" rule in section 84.1 is similar to the function of subsection 212.1(4). While section 84.1 does not contain any exact equivalent to subsection 212.1(4), in very general terms, both the "hard basis" rule in section 84.1 and subsection 212.1(4) can be viewed as provisions that create exceptions where there is a non-arm's length disposition (that would otherwise trigger a deemed dividend) that arises after there has been an arm's length acquisition. As noted above, the fact that a vendor may claim the capital gains exemption in respect of the disposition of the shares is not relevant in the context of an arm's length acquisition under section 84.1. After that acquisition, the acquirer can proceed to implement a non-arm's length disposition that eliminates the PUC deficiency on the acquired shares. Similarly, while not explicit, the underlying rationale of subsection 212.1(4) would appear to include an arm's length indirect acquisition of the shares of a Canadian-resident corporation through a direct arm's length acquisition of the shares of a non-resident corporation that holds the shares of the Canadian-resident corporation, followed by a non-arm's length disposition of the shares of the Canadian-resident corporation from the acquired non-resident corporation to the acquirer Canadian-resident corporation. In that context, as in the context of section 84.1, it would not be relevant whether the vendor in the initial arm's length acquisition claimed or was otherwise entitled to any exemption from Canadian taxation.

In the 1998 federal Budget, it was proposed, among other things, that section 212.1 be amended such that it would not apply in the context of a non-arm's length acquisition where the shares in question constituted "taxable Canadian property" and no treaty exemption applied to the disposition. This proposed amendment was described as follows:

[...] the rule will not apply where the transferred shares are taxable Canadian property on which Canada's right to tax gains is not limited by tax treaty. Where Canada retains the right to tax the transaction as a share disposition generating proceeds of disposition, no tax avoidance exists and thus the recharacterization of the proceeds as taxable surplus may be viewed as unnecessary and inappropriate.

This proposed amendment would have restructured the relationship between Part I and Part XIII of the Act, by giving Part I priority over Part XIII in certain cases. As is the case currently, at that time, any

deemed dividend arising under section 212.1 reduces the vendor's proceeds of disposition as defined in section 54, thereby giving Part XIII priority over Part I.

Ultimately, this proposed amendment was never made, because of a variety of concerns expressed at the time. Thus, although the government became concerned that section 212.1 could itself be used to achieve tax avoidance, it was felt that further study was required. In the news release issued on October 27, 1998, the following comments were made in this regard:

In addition, one part of a set of measures proposed in the budget relating to section 212.1 of the Income Tax Act has been deferred pending further review and consultation. Section 212.1 is an anti-avoidance rule designed to prevent a non-resident shareholder of a Canadian corporation from avoiding Canadian tax on the withdrawal of surplus from the corporation. In certain cases, this anti-avoidance rule itself could inappropriately reduce Canadian tax otherwise payable. The budget therefore proposed, among other changes, not to apply section 212.1 in these cases.

Legislation to implement this part of the proposal will, however, have to both limit the application of this measure to the intended situations, and foreclose other avoidance techniques. To ensure this balance, the measure will be subject to further study, and will not be implemented at this time. The other amendments proposed in the budget regarding the scope of section 212.1 will proceed, and are set out in the draft legislation.

While the related materials were not explicit with respect to the precise concerns that led to this proposed amendment or its deferral, the government appears to have been concerned that it could have had the effect of permitting taxpayers to avoid Part I tax by triggering Part XIII tax through non-arm's length dispositions. Since the rule has never been amended to foreclose that possibility, it may still be a concern.

However, this proposed amendment would not have extended the fundamental scope of section 212.1 to cover arm's length acquisitions, or to condition exclusion of arm's length acquisitions from section 212.1 on the vendor's tax treatment of the disposition, nor would it have revised the scope of subsection 212.1(4).¹⁴ Moreover, in seeking to prevent the application of section 212.1 in respect of non-arm's length dispositions of taxable Canadian property that is not treaty protected, it is clear that the intention was not to provide for relief in the nature of the "hard basis" rule in section 84.1, but rather to preclude the avoidance of Part I tax through the triggering of a section 212.1 deemed dividend. Thus, it is inappropriate to draw any inferences from this proposal about the underlying rationale of subsection 212.1(4) in the context of an arm's length acquisition of the shares of a non-resident corporation followed by a reorganization to combine any Canadian-resident subsidiary of such non-resident corporation with another corporation resident in Canada that controlled the non-resident corporation.

¹⁴ See the more detailed legislative proposals that were issued on October 27, 1998.

3. Paragraph 128.1(1)(c.1)

Paragraph 128.1(1)(c.1) was part of the changes contemplated by the 1998 Federal Budget, along with the proposed amendment to section 212.1 discussed above.

In summary, paragraph 128.1(1)(c.1) provides that if an immigrating corporation owns shares of a corporation resident in Canada, the immigrating corporation is deemed to have received a dividend immediately before the time of disposition arising on immigration equal to the difference between the FMV of the shares of the Canadian-resident corporation and the aggregate of the PUC of those shares and the amount of any gain that arose on their disposition if they constituted taxable Canadian property other than treaty protected property. Such dividend would be subject to withholding tax under Part XIII of the Act. The purpose of this provision was described in the Budget materials as follows:

The current rules are designed to defer, but not eliminate, the taxation in Canada of the immigrating corporation's accrued gains on Canadian property, of its surplus from Canadian business operations, and of the surplus of Canadian corporations of which it is a shareholder. However, the sale of the immigrating corporation's shares, before it becomes resident, to a corporation resident in Canada can frustrate this objective.

Example

A non-resident individual owns all the shares of a non-resident corporation (call it "Forco") whose only property is the stock of a Canadian subsidiary ("Canco"). The individual sells the Forco shares to a new Canadian corporation ("Newco") for Newco shares that have a cost and paid-up capital equal to the fair market value of the Forco shares. Such a sale would generally be non-taxable in Canada, since it involves the sale by a non-resident of shares of a non-resident company. After the sale, Forco becomes resident in Canada, with no effect on the tax cost of its shares in Canco. At this point, the surplus of Canco could potentially be remitted through the (now Canadian) corporate chain as non-taxable dividends, and distributed to the non-resident individual as a tax-free return of capital; alternatively, Newco might be sold to an arm's-length purchaser, with the non-resident individual having precluded the application of Canadian capital gains tax as a result of the fair market value cost base created on the prior sale of the Forco shares to Newco.

Although the general anti-avoidance rule may apply in cases such as this, it is also appropriate to address more specifically the opportunity for such schemes. To that end, the budget proposes that corporations that become resident in Canada after February 23, 1998 be treated as having disposed of all of their property, including Canadian property, at its fair market value at the time of immigration. Where the immigrating corporation owns a share of a corporation resident in Canada (other than a share on which any gain of the immigrating corporation is taxable in Canada), a dividend equal to the amount by which the share's value exceeds its paid-up capital will be deemed to have been paid to the immigrating corporation before it became resident. In this way, the corporation's immigration is treated in the same manner as a sale of the share for fair market value proceeds by the non-resident corporation to a resident company. Finally, the immigrating corporation will be unable to claim an investment allowance under Part XIV of the Act for its last taxation year in which it was non-resident and, as a result, will be held to account for any branch tax arising in the year or deferred in respect of previous years.

This proposed amendment was clearly designed to be coordinated with the proposed amendment to section 212.1 discussed above – which explains the statement that "the corporation's immigration is treated in the same manner as a sale of the share for fair market value proceeds by the non-resident corporation to a resident company". As noted above, the main focus of both amendments was to

ensure that Part I tax could not be avoided on taxable Canadian property other than treaty protected property, although of course the addition of paragraph 128.1(1)(c.1) was also intended to bring the treatment of an immigration into line with the treatment of a non-arm's length disposition under section 212.1 with respect to residual surplus stripping concerns. However, since the proposed amendment to section 212.1 was not ultimately adopted, this intended consistency of treatment was not achieved.

It also is clear that the addition of paragraph 128.1(1)(c.1), just like the proposed amendment to section 212.1, was never intended to affect the treatment of an arm's length acquisition. The example featured in the Budget materials clearly contemplates a series of non-arm's length transactions that are either wholly unconnected to any arm's length acquisition or are carried out by a historical shareholder in advance of an arm's length disposition. In the context of the contemplated alternative involving a series of transactions in advance of an arm's length disposition, it is also clear that the example addresses a historical shareholder with a latent gain on taxable Canadian property, given the statement that "Newco might be sold to an arm's-length purchaser, with the non-resident individual having precluded the application of Canadian capital gains tax as a result of the fair market value cost base created on the prior sale of the Forco shares to Newco." This example does not in any way suggest that the purpose of this provision was to foist the tax cost of the historical shareholder's attribute deficiency onto an arm's length purchaser.

4. Section 212.2

Section 212.2 was also introduced in 1998, in connection with the introduction of section 139.1 and related provisions addressing the "demutualization" of insurance companies.¹⁵ The concern was that demutualization arrangements could otherwise be structured in a manner that would permit Canadian surplus to be extracted without the imposition of non-resident withholding taxes.

The Explanatory Notes released with the initial draft legislation contained the following comments in this regard:

New section 212.2 of the Act is an anti-avoidance rule designed to discourage series of transactions designed so that Canadian corporate surplus distributed to non-residents escapes tax under Part XIII.

This explanation was revised significantly in the Explanatory Notes released with the version of the legislation that was ultimately enacted (S.C. 2000, c. 19 (Bill C-25)):

New section 212.2 of the Act is an anti-avoidance rule designed, in the context of the demutualization of insurance corporations, to discourage transactions designed to allow Canadian corporate surplus to be distributed to non-residents free of tax under Part XIII. (emphasis added)

Although the point is somewhat subtle, it is clear that this difference was intended to reflect certain important and very deliberate changes to the relevant statutory language as between the initial version and the one that was ultimately enacted. This is demonstrable based on a number of comfort letters

¹⁵ See Department of Finance News Release 1998-125, dated December 15, 1998, and related materials.

that were issued by the Department of Finance in this regard in December 1998 and January 1999, as discussed below in greater detail.

Under the initial version of the relevant statutory language, section 212.2 would have been applicable if the following conditions were met (emphasis added):

212.2(1) This section applies where

(a) a taxpayer at a particular time disposes of a share of the capital stock of a corporation resident in Canada (or any property more than 10% of the fair market value of which can be attributed to shares of the capital stock of corporations resident in Canada) to

(i) a person resident in Canada,

(ii) a partnership in which any person resident in Canada has, directly or indirectly, an interest, or

(iii) a person or partnership that acquires the share or the property in the course of carrying on a business through a permanent establishment in Canada, as defined by regulation;

(b) subsection 212.1(1) does not apply to the disposition;

(c) the taxpayer is non-resident at the particular time;

(d) it is reasonable to conclude that the disposition is part of an expected series of transactions or events that includes the issue after ANNOUNCEMENT DATE of a particular share of the capital stock of a particular corporation resident in Canada and

(i) the redemption, acquisition or cancellation of the particular share, or a share substituted for the particular share, by the particular corporation or the issuer of the substituted share, as the case may be,

(ii) an increase in the level of dividends declared or paid on the particular share or a share substituted for the particular share, or

(iii) the acquisition of the particular share or a share substituted for the particular share by

(A) a person not dealing at arm's length with the particular corporation or with the issuer of the substituted share, as the case may be, or

(B) a partnership any direct or indirect interest in which is held by a person not dealing at arm's length with the particular corporation or with the issuer of the substituted share, as the case may be; and

(e) at the particular time, the person described in subparagraph (a)(i) or (iii) or any person who has, directly or indirectly, an interest in the partnership described in subparagraph (a)(ii) or (iii) knew, or ought reasonably to have known, of the expected series of transactions or events described in paragraph (d).

Under this statutory language, the effect of section 212.2 was not confined to the demutualization context, and thus concerns immediately arose that it could be applicable to a wide range of transactions including an arm's length acquisition of the shares of a non-resident corporation that held the shares of a Canadian subsidiary, since paragraph 212.2(1)(a) referred to "any property more than 10% of the fair

market value of which can be attributed to shares of the capital stock of corporations resident in Canada”.

One such transaction was described in considerable detail in a letter dated December 31, 1998 addressed to various officials of the Department of Finance. The Department of Finance responded to this letter by issuing a comfort letter dated January 5, 1999, stating that “We agree that proposed section 212.2 of the Income Tax Act should not apply to the proposed series of transactions described in your letter.”¹⁶ This was also followed by a public announcement on January 14, 1999,¹⁷ as well as revised statutory language. The public announcement made the following comments (emphasis added):

Secretary of State Jim Peterson (International Financial Institutions) today announced plans to better target one of the proposed measures included in the draft income tax legislation on insurance company demutualization released on December 15, 1998.

Demutualization is a process by which mutual companies convert to stock companies. Since December 1997, Canada's four large mutual life insurance companies have announced their intention to pursue demutualization. Legislative changes to allow these companies to demutualize were passed by the House of Commons in December 1998.

The income tax measure in question is proposed section 212.2 of the Income Tax Act. This provision was intended to preclude certain transactions that would have the effect of allowing non-resident persons to receive Canadian corporate surplus distributions on a tax-free basis. However, representations received by the Department have underscored that the proposed measure has broader application than was intended outside the context of demutualization – so that transactions that do not involve the distribution of corporate surplus to non-residents could inadvertently be subject to the proposed measure.

Because of these concerns, the draft legislation on proposed section 212.2 will be revised to limit its application to a series of transactions that includes the issue of shares on a demutualization. The application of this measure outside the context of demutualization will be further reviewed to determine the desirability of its application to certain transactions which could result in corporate surplus stripping.

Mr. Peterson took this opportunity to thank tax professionals for the thoughtful comments received on this measure and to reiterate the Department's interest in receiving further comments on the proposed income tax changes dealing with demutualization.

Accordingly, the conditions to the application of section 212.2 were revised, to limit its scope to the demutualization context, by rewording paragraph 212.2(1)(d) in relevant part as follows (emphasis added):

(d) it is reasonable to conclude that the disposition is part of an expected series of transactions or events that includes the issue after December 15, 1998 of a particular share of the capital stock of a particular insurance corporation resident in Canada on the demutualization (within the meaning assigned by subsection 139.1(1) of the particular corporation...

¹⁶ Reference may also be made to the comfort letters issued by the Department of Finance dated December 24, 1998 and January 14, 1999, as well as to an Advance Income Tax Ruling dated January 1, 1998 (9824483 (E)), and a Supplemental Ruling dated January 1, 1999 (9904553 (E)). There is also an Advance Income Tax Ruling dated January 1, 1998 (9825343 (E)).

¹⁷ See Department of Finance News Release 1999-006, dated January 14, 1999.

This legislative history reflects not an “implied exclusion” but rather a very deliberate “express exclusion” from the scope of section 212.2 of transactions that do not arise in the demutualization context, which was implemented with the very clear knowledge and expectation that section 212.1 would also not apply.

What is also significant is the characterization in general terms of some of these transactions as “transactions that do not involve the distribution of corporate surplus to non-residents”, as well as the general characterization of some of these transactions as “transactions which could result in corporate surplus stripping”. This distinction at a minimum separates a wholly non-arm’s length series of transactions from a series of transactions implemented by arm’s length purchasers in order to obtain and preserve cross-border PUC equivalent to the fresh capital invested by them in relation to direct or indirect acquisitions of corporations resident in Canada.

5. Section 212.3

Section 212.3 was introduced in 2012, as announced by the 2012 Federal Budget. In brief, this measure has a dual purpose – on the one hand to indirectly address what is referred to as “debt dumping”, and on the other hand to address non-Canadian deployments of surplus which are perceived to be analogous to “surplus stripping” on the basis that they are not “more closely connected” to the Canadian business activities of the relevant corporation resident in Canada (the “CRIC”). Because of this dual purpose, and because of its complexity, the measure is somewhat awkward and can give rise to results that are over-inclusive or under-inclusive, and even duplicative.¹⁸

However, in essence, the measure is clear – it is aimed at circumstances in which perceived tax base erosion is achieved through certain long-term “investments” in foreign affiliates by a CRIC that is controlled by a non-resident corporation (the “Non-Resident Parent”). It is also clear that this measure is not intended to compromise the ability of a Non-Resident Parent to use a freshly capitalized Canadian acquisition company in order to implement an arm’s length acquisition and thereby obtain and preserve cross-border PUC equal to the net FMV of Canadian assets that it indirectly acquires. This is demonstrable based on a review of certain structural features of this measure, as well as a number of statements that have been made in this regard.

Firstly, the measure does not in general apply where a Non-Resident Parent uses a freshly capitalized Canadian acquisition company in order to implement an arm’s length acquisition of a corporation resident in Canada unless more than 75% of the underlying asset base of the Canadian target consists of shares of foreign affiliates. Even in that case, the effect of the rule in paragraph 212.3(2)(b) is to suspend only such portion of the PUC of the Canadian acquisition company as “can reasonably be considered to relate to the investment” in the underlying shares of foreign affiliates.¹⁹ If the 75% threshold is not breached, then the PUC of the Canadian acquisition company remains fully preserved.

¹⁸ The initial version of this regime was reformulated before being enacted, and even the reformulated version that was enacted has been amended (see S.C. 2014, c. 39) and continues to be reviewed for further refinement.

¹⁹ This is also made clear in the Explanatory Notes that relate to paragraph 212.3(2)(b).

Secondly, if the 75% threshold is breached but the shares of the foreign affiliates are subsequently distributed or otherwise disposed of (e.g., in a post-acquisition reorganization),²⁰ subject to certain exceptions, then the PUC of the Canadian acquisition company is “reinstated” under subsection 212.3(9), which is why we say above that the initial effect of the rule in paragraph 212.3(2)(b) is to *suspend* the PUC rather than to *eliminate* it. Together, these two features of the measure make it perfectly clear that it is not intended to compromise the ability of a Non-Resident Parent to use a freshly capitalized Canadian acquisition company in order to implement an arm’s length acquisition and thereby obtain and preserve cross-border PUC equal to the net FMV of Canadian assets that it indirectly acquires.

Thirdly, as illustrated by the CRA’s example from the 2014 Canadian Tax Foundation Conference in Vancouver, the relevant rules produce exactly the same ultimate result where a Non-Resident Parent uses a freshly capitalized Canadian acquisition company in order to implement an arm’s length acquisition of a non-resident target that holds a Canadian subsidiary and thereby obtain and preserve cross-border PUC equal to the net FMV of Canadian assets that it indirectly acquires. This is logical, because the economic substance of all of these alternatives is the same – so the ultimate result from a tax perspective should also be the same. The only situation that seems to deviate from the result of obtaining and preserving PUC equal to net FMV of Canadian assets is where a Canadian target holds foreign affiliates that are not more closely connected to its own Canadian business operations but the 75% threshold is not breached – in which case PUC is preserved in an amount exceeding the net FMV of the Canadian assets – unless the Non-Resident Parent nevertheless proceeds with a “bump and strip” and thereby reduces the PUC of the Canadian acquisition company down to the amount of net FMV of the Canadian assets.²¹

Fourthly, it is also clear that circumstances can arise that are even more complex than those described above. For example, a Non-Resident Parent can use a freshly capitalized Canadian acquisition company to acquire a Canadian target that holds a foreign affiliate that in turn holds a Canadian subsidiary. The ultimate result should be the same from a tax perspective in this scenario as in the others considered above – the Non-Resident Parent should be permitted to obtain and preserve cross-border PUC equal to the net FMV of Canadian assets that it indirectly acquires, and it should not be required to bear the tax cost of any attribute deficiency present in the pre-acquisition structure. We note that paragraph 88(1)(d) allows an increase to the cost base of Canadian target’s shares in its foreign affiliate, and that Canadian target should qualify as a “designated acquired corporation” (as defined in subsection 95(1)) for the purposes of the “carve-out” rule in paragraph 95(2)(f.1) such that no FAPI would arise in respect of any pre-acquisition period gain on the shares of the Canadian subsidiary held by the Canadian target’s foreign affiliate.

Finally, we observe, with reference to all of these examples, that the Act in general does try to align the treatment of indirect transactions with the treatment of direct transactions. While this alignment is not

²⁰ Or other transactions such as distributions made from the foreign affiliate.

²¹ The CRA has also made statements that address certain practical considerations that arise in the context of a “bump and strip” transaction – in light of new Regulation 5907(5.4). See CRA Document 2011-0404521C6 dated May 19, 2011. It is clear that the expectation in that context would be that the Canadian acquisition company would have sufficient PUC to support the post-acquisition distribution of the underlying foreign affiliates.

always perfect, the architecture of the Act does in general try to prevent taxpayers from doing indirectly what they are not permitted to do directly, but also to permit taxpayers to do indirectly what they are permitted to do directly. This is the underlying rationale of subsection 212.1(4) – to permit an arm’s length purchaser to achieve the same ultimate treatment in respect of an indirect acquisition of a Canadian subsidiary held by a directly-acquired foreign target as the purchaser would obtain in respect of a direct acquisition of the Canadian subsidiary.